

DRAFT – FOR DISCUSSION PURPOSES ONLY

**NEW YORK STATE RELIABILITY COUNCIL, L.L.C.  
("NYSRC")  
POLICY NO. 5-~~12~~13**

**PROCEDURE FOR ESTABLISHING  
NEW YORK CONTROL AREA  
INSTALLED CAPACITY REQUIREMENTS**

DRAFT ICS Proposal ~~April 4~~May 5, 2018

## Table of Contents

### Contents

Table of Contents .....	2
Section 1: Introduction .....	4
Section 2: Overview of the Reliability Calculation Process .....	4
2.1 Calculation Process .....	4
2.2 Timeline .....	5
2.3 IRM Study Reporting Requirements.....	7
Section 3: Reliability Calculation .....	7
3.1 NYSRC Resource Adequacy Criterion .....	7
3.2 Computer Program Used for Reliability Calculation.....	7
3.3 NYCA Zones and External Areas Representation .....	9
NYCA ZONES .....	9
3.4 Conduct of the MARS Analysis .....	10
3.4.1 Unified Method for Establishing IRM Requirements .....	10
3.4.2 Base Case IRM Anchoring Methodology.....	11
3.5 Input Data and Models .....	11
3.5.1 NYCA Load Model.....	12
3.5.2 NYCA Capacity Model.....	13
3.5.3 Emergency Operating Procedures (EOPs).....	15
3.5.4 Transmission System Model .....	15
3.5.5 Locational Capacity Requirements.....	16
3.5.6 External Control Area Load and Capacity Models .....	16
3.6 Sensitivity Analysis .....	17
3.7 Data Base Confidentiality .....	18
3.8 Standard Error .....	18
3.9 Data Base Quality Assurance.....	19
Section 4: Responsibilities .....	20
4.1 Installed Capacity Subcommittee.....	20
4.2 NYISO .....	20
4.3 Market Participants.....	21
4.4 NYSRC Executive Committee .....	21
Section 5: Establishment of the Final IRM .....	22
5.1 Consideration of IRM Study Results .....	22
5.2 Executive Committee IRM Voting Procedure .....	22
APPENDIX A: Unified Methodology Description .....	25
2.0 Initial Conditions .....	25
3.0 Setting up the base case model for a desired study reserve margin (SRM) .....	25
4.0 Determination of the initial target capacity for each locality.....	26
5.0 Determination of the capacity multiplier for each locality .....	26
6.0 Determination of the actual capacity removal or addition for each locality .....	27
7.0 The locational capacity requirement (LCR) for each identified locality .....	27
8.1 Determination of the LCR-IRM curves.....	27
APPENDIX B: IRM Anchoring Method .....	28

**DRAFT – FOR DISCUSSION PURPOSES ONLY**

APPENDIX C: Alignment Process ..... 30  
    Establishing Final IRMs above the Study’s Base Case Results ..... 30  
    Establishing Final IRMs below the Study’s Base Case Results..... 30  
The aligned base case database is used by the NYISO as a reference for their studies. .... 30  
APPENDIX D: EFORD ..... 31  
    Introduction ..... **Error! Bookmark not defined.**  
    Assumptions for the Methodology ..... **Error! Bookmark not defined.**  
    Development of the Methodology..... **Error! Bookmark not defined.**  
    MARS Transition Rate Methodology ..... **Error! Bookmark not defined.**  
    Implementation and Validation of the MARS Transition Rate Methodology**Error! Bookmark not defined.**  
    References ..... **Error! Bookmark not defined.**

## Section 1: Introduction

The reliable supply of electric services within the New York Control Area (NYCA) depends on adequate and dependable generation and transmission facilities. This policy focuses on the supply of electricity; specifically, the process that will be followed by the New York State Reliability Council (NYSRC) for determining and setting the amount of resource capacity required to ensure an acceptable level of service reliability in the NYCA.

The general requirements and obligations concerning NYCA resource adequacy and Installed Capacity Requirements (ICR) are defined in the New York State Reliability Council (NYSRC) Agreement and the New York Independent System Operator (NYISO)/NYSRC Agreement. Under these Agreements the NYSRC is responsible for calculating and establishing the amount of resource ICR to meet NYSRC Reliability Rules. In compliance with this obligation, the NYSRC Executive Committee approves an NYCA required Installed Reserve Margin (IRM) requirement for the following May through April capability year. The ICR relates to the IRM through the following equation:

$$\text{ICR} = (1 + \text{IRM}\%/100) \times \text{Forecasted NYCA Peak Load}$$

The final NYCA IRM requirement, as approved by the NYSRC Executive Committee, is the basis for various installed capacity analyses conducted by the NYISO. These NYISO analyses include the determination of the capacity obligation of each Load Serving Entity (LSE) on a Transmission District basis, as well as Locational Installed Capacity Requirements, for the following capability year. These NYISO analyses are conducted in accordance with NYSRC Reliability Rules and Procedures.

## Section 2: Overview of the Reliability Calculation Process

This section provides an overview of the NYSRC reliability calculation process, including the major modeling parameters for establishing statewide IRM requirements, a timeline for this process, and reporting requirements for the technical IRM study (IRM Study).

### 2.1 Calculation Process

The reliability calculation process for determining the NYCA IRM requirement utilizes a probabilistic approach. This technique calculates the probabilities of outages of generating units, in conjunction with load and transmission models, to determine the number of days per year of expected capacity shortages. The General Electric Multi-Area Reliability Simulation (MARS) is the primary computer program used for this probabilistic analysis. The result of the calculation is termed Loss of Load Expectation (LOLE), which provides a consistent measure of system reliability. The relationship between MARS and the various models used in the NYCA IRM calculation process is depicted in Figure 2-1. The Installed Capacity Subcommittee (ICS) of the NYSRC has the responsibility of monitoring these studies and preparing reports for establishing NYCA ICR.

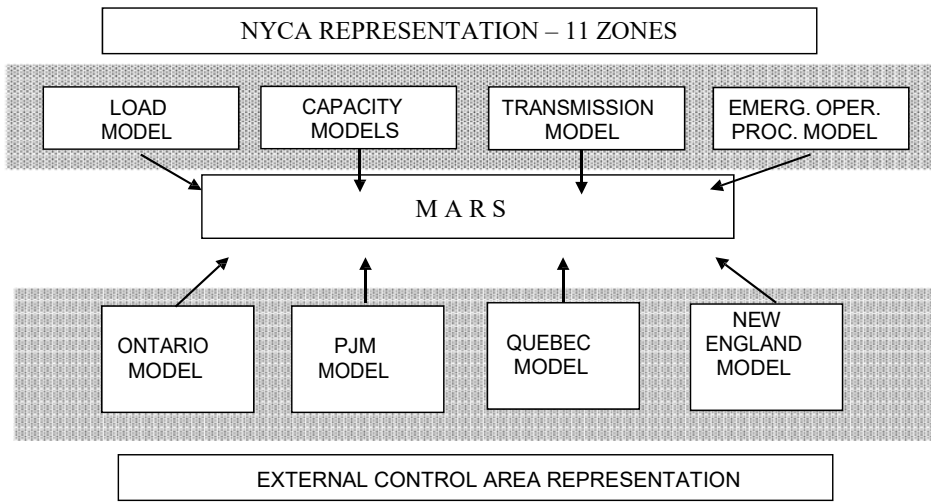

**Figure 2-1: Relationship between MARS and the Models Used In the IRM Requirement Calculation Process**

## 2.2 Timeline

A timeline for establishing NYCA IRM requirements is shown in Table 2-1 top of the next page. This timeline is based on adopting an IRM in early December in order to provide the NYISO with next year’s NYCA IRM requirement in sufficient time to recognize the NYISO’s need to complete its installed capacity and procurement process and begin its studies for determining the following summer’s LSE capacity obligations.

Adherence to this schedule is necessary to support the NYSRC annual filing with FERC to advise FERC of the annual state-wide IRM requirement for the New York Control Area for the following capability year if needed to seek FERC approval of any revision to the IRM requirement, and to notify the NYISO so that its capacity commitment schedule can be met.

**DRAFT – FOR DISCUSSION PURPOSES ONLY**

**Table 2-1  
Timeline for the Establishment  
of the  
NYCA Installed Capacity Requirements**

<b>Monthly Meeting</b>	<b>Event/Deadline</b>	<b>Section References</b>
February	➤ Begin development of IRM study base case assumptions matrix, including input data and modeling enhancements (ICS/NYISO).	3.5
	➤ Identify potential major modeling enhancements and begin preparation of white papers (ICS/NYISO).	3.5
March	➤ Begin preparation of transmission topology (NYISO).	3.5.4
May	➤ Complete development of new major models and approve related white papers (NYISO/ICS).	3.5
June	➤ Benchmark new MARS version received from GE (NYISO).	3.2
	➤ NYISO completes transmission topology and delivers to ICS.	3.5.4
	➤ From modeling enhancement white papers, identify which will be used for this year’s IRM study and which that need an additional year before implementation (ICS).	3.5
July	➤ New model representations received from External Areas (NYISO).	3.5.6
	➤ If applicable, approve use of new MARS version for this year’s study (ICS).	3.2
	➤ Complete calculation of IRM impacts of major modeling enhancements (NYISO).	3.5
	➤ Approve transmission topology (ICS).	3.5.4
August	➤ Begin data quality assurance reviews (NYISO/GE/TOs).	3.8
	➤ Approve preliminary base case assumptions matrix, including new major models (ICS/Executive Committee [EC]).	3.5
	➤ Complete parametric studies (NYISO).	3.4
September	➤ Begin preliminary base case study (NYISO).	3.4
	➤ Approve list of sensitivity cases (ICS/EC)	3.6
	➤ Approve preliminary base case study (ICS).	3.4
October	➤ Begin sensitivity testing (NYISO).	3.6
	➤ Fall NYCA load forecast delivered to ICS from NYISO	3.5.1
	➤ Base Case assumptions lock-down (ICS)	3.6
	➤ Approve Final base case assumptions matrix (ICS/EC)	3.5
	➤ Begin preparation of base case study (NYISO).	3.4
	➤ Begin preparation of draft IRM report (ICS).	2.3
	➤ Complete data quality assurance reviews (NYISO/GE/TOs).	3.8
➤ Review sensitivity results (ICS).	3.6	
November	➤ Complete Draft IRM study report (ICS).	2.3
	➤ Approve Base case IRM (ICS/EC).	3.4
	➤ If required prepare Special Sensitivity Case (includes all assumption changes after assumption lock-down)(ICS/NYISO)	3.6
December	➤ Complete Final IRM study report (ICS).	2.3
	➤ Approve sensitivity results (ICS/EC). Approve Final IRM Study (EC).	3.6
	➤ Final IRM adopted (EC)	3.4
	➤ Issue letter to the NYISO CEO, press release, and IRM filing to FERC (if needed) announcing final IRM (EC)	5.0 4.4
	➤ Complete base case alignment study (ICS)	3.5.5

## 2.3 IRM Study Reporting Requirements

In accordance with the NYSRC Reliability Rules, the NYSRC prepares the IRM Study, a technical report providing the assumptions, procedures, and results of analyses for determining NYCA IRM requirements. Drafts of this report are posted on the NYSRC web site and comments from all market participants are solicited during the NYCA IRM determination process in accordance with NYSRC Openness Policy 2.

## Section 3: Reliability Calculation

This section contains the criterion used for calculating the required NYCA IRM level, a description of the reliability calculation, including the primary computer program used, and a description of the input data and models used in the reliability calculation. Section 5 will cover the process for establishing the final IRM requirement for the following capability year, which evaluates the base case and sensitivity case results determined by the reliability calculation described in Section 3.

### 3.1 NYSRC Resource Adequacy Criterion

The acceptable LOLE reliability level in the NYCA is stated in the NYSRC Reliability Rules. NYSRC Reliability Rule A-R1, *Statewide Installed Reserve Margin Requirements*, states:

*The NYSRC shall establish the IRM requirement for the NYCA such that the probability (or risk) of disconnecting any firm load due to resource deficiencies shall be, on average, not more than once in ten years. Compliance with this criterion shall be evaluated probabilistically, such that the loss of load expectation (LOLE) of disconnecting firm load due to resource deficiencies shall be, on average, no more than 0.1 day per year. This evaluation shall make due allowance for demand uncertainty, scheduled outages and deratings, forced outages and deratings, assistance over interconnections with neighboring control areas, NYS Transmission System transfer capability, and capacity and/or load relief from available operating procedures.*

This Rule is consistent with the NPCC Resource Adequacy Criterion and may be modified from time to time, as appropriate, in accordance with the NYSRC open process procedure for modifying NYSRC Reliability Rules (NYSRC Policy 1). The NYS Transmission System transfer capability in the above Reliability Rule is represented using emergency transfer limits.

### 3.2 Computer Program Used for Reliability Calculation

The primary tool used in the probabilistic analysis for establishing NYCA IRM requirements is a General Electric computer program called the Multi-Area Reliability Simulation (MARS). This program includes a detailed load, generation, and transmission representation for 11 NYCA zones (A through K), as well as the four external Control Areas interconnected to the NYCA (see Section 3.3 for a description of these zones and Control Areas).

## DRAFT – FOR DISCUSSION PURPOSES ONLY

A sequential Monte Carlo simulation forms the basis for MARS. The Monte Carlo method provides a fast, versatile, and easily expandable program that can be used to fully model many different types of generation and demand-side options.

The MARS program calculates the standard reliability indices of daily and hourly LOLE (days/year and hours/year) and Loss of Energy Expectation (LOEE in MWh/year). The use of sequential Monte Carlo simulation allows for the calculation of time-correlated measures such as frequency (outages/year) and duration (hours/outage). The program also calculates the need for initiating Emergency Operating Procedures (EOPs), expressed in days/year (see Section 3.5.3).

In addition to calculating the expected values for the reliability indices, MARS also produces probability distributions that show the actual yearly variations in reliability that the NYCA could be expected to experience.

In determining the reliability of the NYCA there are several types of randomly occurring events that must be taken into consideration. Among these are the forced outages of generating units and transmission capacity. Monte Carlo simulation models the effects of such random events. Deviations from the forecasted loads are captured by the use of a load forecast uncertainty model.

Monte Carlo simulation approaches can be categorized as “non-sequential” and “sequential”. A non-sequential simulation process does not move through time chronologically or sequentially, but rather considers each hour to be independent of every other hour. Because of this, non-sequential simulation cannot accurately model issues that involve time correlations, such as maintenance outages, and cannot be used to calculate time-related indices such as frequency and duration.

A sequential Monte Carlo simulation, the approach used by the MARS program, steps through the year chronologically, recognizing the fact that the status of a piece of equipment is not independent of its status in adjacent hours. Equipment forced outages are modeled by taking the equipment out of service for contiguous hours, with the length of the outage period being determined from the equipment’s mean time to repair. The sequential simulation can model issues of concern that involve time correlations, and can be used to calculate indices such as frequency and duration. It also models transfer limitations between individual areas.

Because the MARS Program is based on a sequential Monte Carlo simulation, it uses state transition rates, rather than state probabilities, to describe the random forced outages of the thermal units. State probabilities give the probability of a unit being in a given capacity state at any particular time, and can be used if one assumes that the unit’s capacity state for a given hour is independent of its state at any other hour. Sequential Monte Carlo simulation recognizes the fact that a unit’s capacity state in a given hours is dependent on a given state in previous hours and influences its state in future hours. It thus requires additional information that is contained in the transition rate data.

If an updated MARS software version becomes available by June 1, prior to the conduct of IRM study cases, ICS should consider its use for conducting the study. The decision to select a new MARS version depends on desirable improvements in the reliability calculation process or correction of program errors in the new version. If there is a decision to utilize a new MARS version, it must be tested and benchmarked by the NYISO to ensure that it produces acceptable



results. Such tests normally compare results for reasonableness with study results from a previous MARS version using the same assumptions. If a new MARS version becomes available after commencement of IRM study cases, it may be considered for use for the following IRM study.

### 3.3 NYCA Zones and External Areas Representation

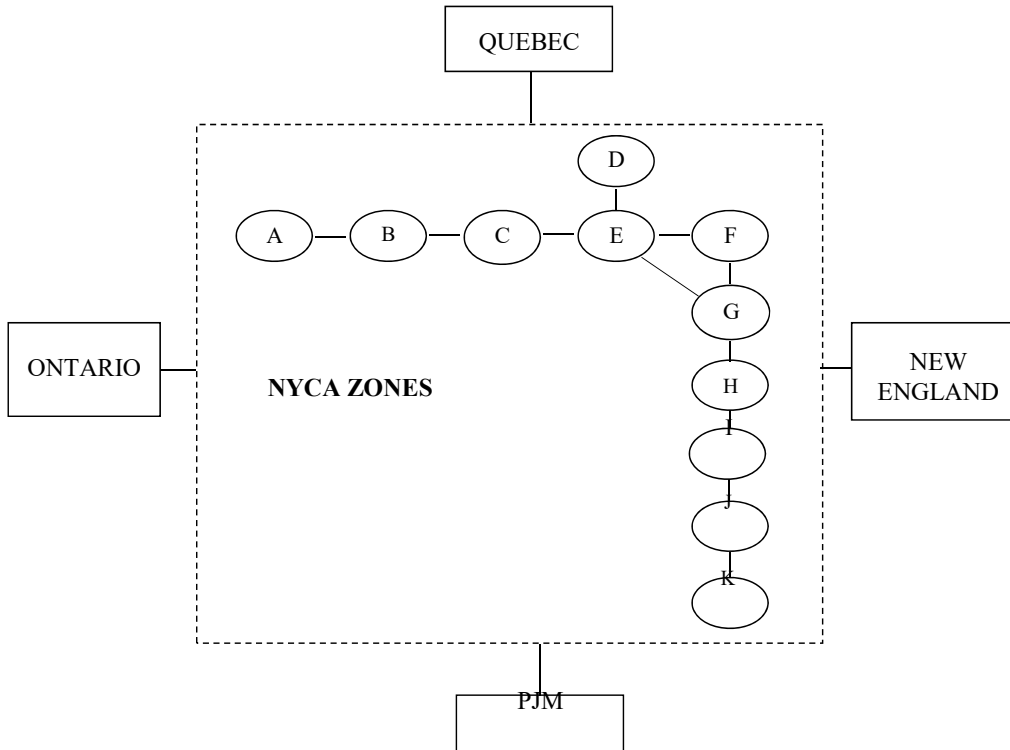

Figure 3-1: Simplified MARS Representation of NYCA Zones & External Control Areas

### 3.4 Conduct of the MARS Analysis

Each year’s MARS IRM analysis develops both a *preliminary base case* and a *final base case*.

#### The Preliminary Base Case.

The preliminary base case is developed by starting with the previous year’s final base case and inputting base case changes one parameter at a time. The LOLE results of each of these “parametric analysis” simulations are reviewed to confirm that the reliability impact of the change is reasonable and explainable. In addition, parametric results are used to show the incremental IRM change impact for individual parameters from the IRM for the previous capability year. This base case incorporates a preliminary peak load forecast (see Section 3.5.1). The preliminary base case is used to conduct sensitivity studies (see Section 3.6).

#### The Final Base Case

The final base case is prepared following receipt of the NYISO’s fall load forecast (see Section 3.5.1). The final base case may also include data changes resulting from quality assurance reviews. The final base case is used to calculate the final IRM. The final base case includes updates or corrections, approved by ICS, which have occurred since the preliminary base case.

#### 3.4.1 Unified Method for Establishing IRM Requirements

The procedure utilized for establishing NYCA IRM requirements is termed the *Unified Method* because it provides a coordinated approach that can also be used by the NYISO for its analysis of Locational Capacity Requirements (LCRs<sup>1</sup>). The Unified Method reflects a graphical relationship between NYCA IRM and the LCRs as depicted graphically in Figure 3-2.

Under this method capacity is removed from zones west of the Central-East interface that have excess capacity when compared to their forecast peaks until a study point IRM is reached. At this point, capacity is shifted from Zones J and K into the same zones as above until the 0.1 LOLE criterion is violated. Doing this at various IRM points yields a curve such as depicted in Figure 3-2, whereby all points on the curve meet the NYSRC 0.1 days/year LOLE criterion. Furthermore, all LCR “point pairs” for NYC and LI curves along the IRM axis represent a 0.1 LOLE solution for NYCA. Appendix A provides a detailed description of the Unified Method.

---

<sup>1</sup> NYSRC Policy 5 does not specify the method by which the final LCRs are set. Rather, the NYISO determines the final LCRs for all Localities through its tariff and procedures. The LCRs set by the NYISO must be consistent with the state-wide IRM adopted by the NYSRC.

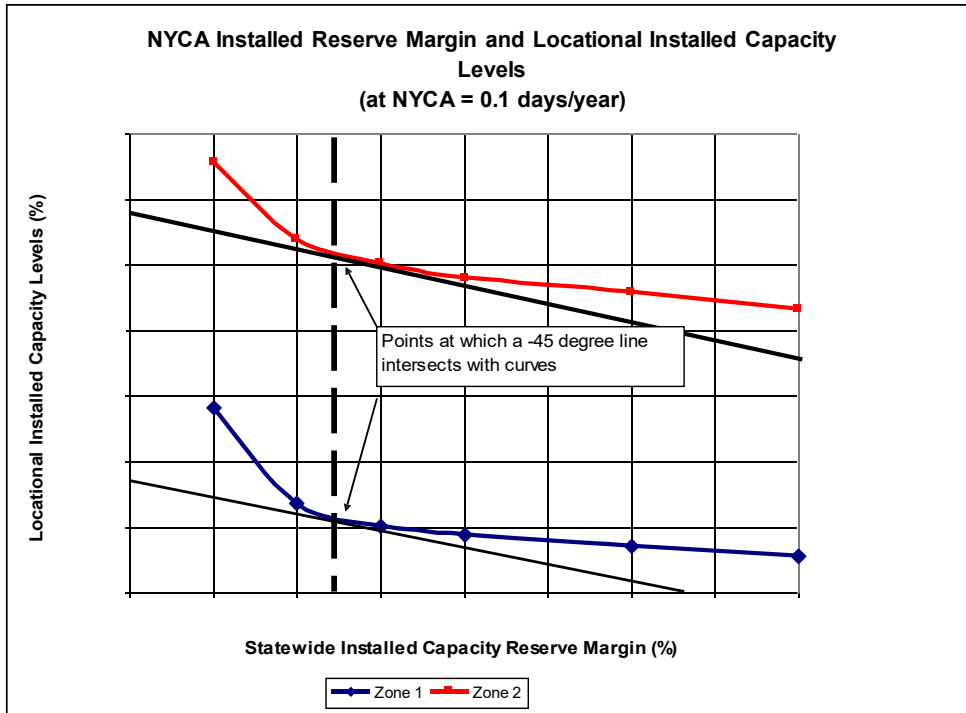

Figure 3-2: Unified Curve and IRM Anchor Point

### 3.4.2 Base Case IRM Anchoring Methodology

This method establishes base case NYCA IRM requirements and related minimum LCRs from IRM/LCR curves established by the Unified Method described in Section 3.4.1. The *anchor point* on the curve in Figure 3-2 is selected by applying a tangent of 45 degrees (“Tan 45”) analysis at the bend (or “knee”) of the curve. Points on the curve on either side of the Tan 45 point may create disproportionate changes in LCR and IRM, since small changes in LCR can introduce larger changes in IRM Requirements and vice versa. Appendix B describes the mathematical analysis for selecting Tan 45 points on the curves. Alternative anchoring methods will be periodically evaluated.

### 3.5 Input Data and Models

This section describes the load, capacity, and transmission models that are input to the MARS program for determining NYCA IRM requirements.

The input data and models used for an IRM study’s base case are incorporated into an *Assumptions Matrix* which is prepared early in the study process as this information becomes available (see Table 2-1). Before any proposed major enhancement of a model is accepted for use in the base case, it is given a thorough review. The review includes testing of the proposed enhancements and may include the preparation of a white paper. If it is found that a proposed

## DRAFT – FOR DISCUSSION PURPOSES ONLY

model enhancement cannot be developed in time for the next IRM study, its implementation may be delayed to the following year's IRM study. The IRM Study model base case reflects those resource and transmission system changes that are received by the study input cutoff date and that will be effective on June 1 of the Capability Year to be studied.

Preliminary base case assumptions are approved by ICS and the Executive Committee in early July. Final base case assumptions, including assumption changes that may occur after approval of the preliminary base case assumption matrix, are approved in early October. Substantive assumption changes that are identified after final base case assumption approval (base case assumption “lock-down”) are combined into a single Special Sensitivity Case (see Table 2-1 and Section 3.6) that is approved by ICS.

### 3.5.1 NYCA Load Model

The NYCA load model consists of the forecast NYCA and zone peak loads for the next capability year, and load shape and load uncertainty models.

#### Peak Loads

The NYISO provides peak and zone load forecasts for the next capability period. The NYISO will provide a preliminary load forecast – as published in the NYISO “Gold Book” – to ICS as part of an initial data base for use in the preliminary base case. This load forecast could be adjusted, if necessary, to account for resources that do not participate in the wholesale markets. Following the summer period, the NYISO develops a fall forecast recognizing actual load conditions experienced during this most recent summer. This forecast should be available to the NYSRC by October 1 for use in the final base case (see Section 2.2).

#### Load Shape Model

The yearly load shapes that are input to the MARS program consist of multiple 8,760 hour chronological models. The appropriate load shape years used for the IRM study are developed by NYISO and reviewed by ICS. In making its determination, the NYISO may consider historical NYCA and zonal load shapes, weather characteristics, and other statistics from a minimum of the past ten years. After consultation with the NYISO, the ICS adopts the appropriate load shape years for the IRM study.

Since historical load shapes may contain peaks that differ from the upcoming year forecast (historical shapes usually contain peaks at a lower level than the forecast), the chosen shapes may be adjusted to accommodate the zonal and system forecast peaks.

#### Load Forecast Uncertainty Model

The load forecast uncertainty (LFU) model captures the impacts of weather conditions on future loads. The LFU gives the MARS program information regarding seven load levels (three loads lower and three loads higher than the median peak) and their respective probabilities of occurrence. For each modeled hour, the MARS program determines the resource adequacy and calculates an average loss of load expectation for the capability year for each of the seven load levels. MARS uses this information to evaluate a probability weighted-average LOLE for each area. Recognizing the unique LFU nature of individual NYCA zones, the LFU model is subdivided into five separate areas: New York City (Zone J), Long Island (Zone K), Zones H and I, Zones F and G, and the rest of New York State (Zones A-E).

## DRAFT – FOR DISCUSSION PURPOSES ONLY

Preparation of the LFU model is coordinated by the NYISO in collaboration with the TOs. The process used to develop the LFU model generally follows the procedure used to calculate the forecasted NYCA ICAP peak as described in the *NYISO Load Forecasting Manual*. This process follows the development of the NYCA peak, insofar as the LFU is a distribution, not a point estimate. Following acceptance from the NYISO Load Forecasting Task Force, the NYISO submits the final LFU model to be used in MARS to ICS for review and approval. The LFU model is built in three steps: The first step creates a relationship between a weather metric and the summer peak load for each zone using as many years of historical data as is available. The second step relates the same weather metric with the daily peak load historical data of selected years that are not older than 10 years. The third step combines the correlations found in the first and second steps to produce a relationship of expected yearly peak load in a per unit base and its probability of occurrence.

### 3.5.2 NYCA Capacity Model

The capacity model input to MARS incorporates the several types of resource capacity used to serve load in the NYCA. This section describes how each resource type is modeled in MARS.

#### Generating Units

The capacity model includes all NYCA generating units, including new and planned units, as well as units that are physically outside New York State. The IRM study base case will be updated for generating unit additions and removals consistent with the current Load and Capacity Data Report (“Gold Book”). In addition, the NYISO, pursuant to its procedures and tariffs, will identify the generating units that are eligible to participate in the NYISO’s ICAP market and recommend to the NYSRC the inclusion or removal of such units in the IRM base case. The ICS may request the NYISO to provide information concerning its application of its procedures and tariffs.

The capacity model requires the following input data:

*Unit Ratings.* The rating for each generating unit is the smaller of the reported Dependable Maximum Net Capability (DMNC) rating or the Capacity Resource Interconnection Service (CRIS) value. The annual NYCA Load and Capacity Report, issued by the NYISO, is the source of those generating units and their ratings included in the capacity model.

*Unit Performance.* Performance data for all thermal generating units, as well as the Niagara and St. Lawrence hydroelectric projects, includes forced and partial outages, which are captured by inputting a multi-state outage model that is representative of the “equivalent demand forced outage rate” (EFORD) for each unit represented. The MARS program uses state transition rates and the development of generator transition rates matrices. The source of this data is outage information collected by the NYISO from generator owners using availability data reporting requirements in the NYISO Installed Capacity Manual. The multi-state model for each unit is derived from the collection of forced and partial outages that occur over the most recent five-year period using benchmarked GADS Open Source (OS) software as described in Appendix E. The appropriate historical time period should be periodically evaluated.

In addition to using actual outage data as the basis for representing EFORDs in the capacity model, there are two circumstances when non-historic data may be used. First, the performance projection for a new or planned unit should be based on NYCA experience with similar units and/or NERC class-averages for the type and size of the unit. Second, the NYISO utilizes a

## DRAFT – FOR DISCUSSION PURPOSES ONLY

GADS screening process for reviewing the accuracy of outage data it has collected from Generator Owners. From the results of this screening process, the NYISO may recommend to ICS the replacement of misreported or suspect data with proxy data.

Another generating unit performance parameter to be modeled for each unit is scheduled maintenance. This parameter includes both planned and maintenance outage components. The planned outage component is obtained from the generator owners, and where necessary, extended so that the scheduled maintenance period equals the historical average using the same period used to determine EFORd averages.

The historical summer maintenance is also reviewed to determine, on average, how many MW were on a maintenance outage on high load days. This value is used to determine how many generating units should be modeled on maintenance over the summer peak load period. For purposes of this review, the summer peak load period is July, August, and September up to Labor Day of the Capability Year being studied.

*Thermal Unit Output Correction when Design Temperature Conditions are Exceeded.* Models of thermal unit deratings due to temperature in excess of DMNC test conditions are developed based on two parameters. The first parameter relates NYCA load to temperature, while the second parameter relates thermal unit deratings to temperatures above DMNC conditions.

*Intermittent Resources.* Wind, solar, and run-of-river hydroelectric units are intermittent renewable resources that are modeled as hourly load modifiers. The output of these facilities is based on production profiles derived from existing facilities operating within the NYCA over the same five-year period that is used for thermal units.

### Special Case Resources and Emergency Demand Response Program

Special Case Resources (SCRs) are loads capable of being interrupted on demand, and distributed generators, rated at 100 kW or higher, that are not visible to the NYISO's Market Information System. The Emergency Demand Response Program (EDRP) is a separate program that allows registered interruptible loads and standby generators to participate on a voluntary basis and be paid for their ability to restore operating reserves.

The capacity from these programs is based on NYISO projections for the coming capability period. These projections are based upon escalating the Installed Capacity level of the current year's SCR program by the average annual growth rate in the Installed Capacity level of the SCR program over the past three years.

Due to the possibility that some of the potential SCR and EDRP program capacity may not be available during peak periods, NYISO projections are discounted based on previous experience with these programs (including years where there have been demand response events) as well as any operating limitations. Both EDRP and SCR programs are modeled as EOP steps, with a maximum number of calls per month so designated for EDRP programs. SCRs, however, because of their obligatory nature, are considered capacity resources in setting the IRM, while EDRP, like other EOP steps such as voltage reductions, are not considered capacity resources.

### Unforced Capacity Deliverability Rights (UDRs)

## DRAFT – FOR DISCUSSION PURPOSES ONLY

UDRs are capacity rights that allow the holder/owner to receive the Locational Capacity Benefit derived by the NYCA from the addition of a new incremental controllable transmission project that provides a transmission interface to a NYCA locality or zone. The owner/holder of these UDR facility rights must designate how they will be treated by the NYSRC and NYISO in the NYCA IRM and LCR studies, in accordance with the time schedule specified in the NYISO ICAP Manual. The NYISO calculates the actual UDR award based on the transfer capability of the facility and other data.

The holder/owner of the UDR facility currently has the option on an annual basis of selecting the MW quantity of UDRs (ICAP) it plans on utilizing for capacity contracts over its controllable line which counts towards meeting locational and installed capacity requirements, with any remaining capability on the controllable line used to support emergency assistance.

### External Installed Capacity from Contracts

~~An input to the study is the amount of NYCA installed capacity that is assumed to be located outside of NYCA. Some of this capacity is grandfathered. The amount of external capacity imports modeled in the IRM study is limited to the grandfathered contracts. The NYISO, during its import rights processes, will allow additional imports of MW to the extent it would not impact the IRM results, per NYSRC Reliability Rule A.2, and as determined in accordance with its rules and procedures.~~

### Sales

The NYISO presents to ICS the inter-area capacity transactions to be modeled in the study.

### Environmental Regulations

Environmental regulations may restrict the availability of generating units during certain time periods. Accordingly, the capacity model reflects implementation of environmental initiatives. The NYISO Reliability Needs Assessment (RNA) or other NYISO references are used as the source for developing appropriate generating unit performance models for recognizing environmental regulation impacts.

### **3.5.3 Emergency Operating Procedures (EOPs)**

The NYISO initiates emergency steps when its operating reserve levels approach critical levels. Such EOPs are modeled in IRM studies. The EOP steps consist of those load control and generation supplements that can be implemented before load must be disconnected due to capacity shortages. Load control measures include implementation of SCR and EDRP programs, public appeals to reduce demand, and voltage reduction. Generation supplements could include emergency purchases and cutting operating reserves. The benefit from each of these emergency steps can either be expressed as a percentage of load or in MW. The NYISO recommends to ICS the EOP steps and related capacity values to be represented in the base case, based on operating experience with these measures.

### **3.5.4 Transmission System Model**

The transmission system is modeled through emergency transfer limits in the interfaces between pairs of NYCA zones, or between NYCA zones and external Control Areas. These emergency transfer limits are developed in accordance with NYSRC Reliability Rules B.1, B.2 and B.3, Thermal, Voltage and Stability Assessments, respectively. The transfer limits are specified for each direction of the interface. Forced outage rates on cable interfaces in southeast

## DRAFT – FOR DISCUSSION PURPOSES ONLY

New York are modeled in the same manner as generating unit outages, through the use of transition rates. These outage rates are determined and provided by the transmission owners. Certain interfaces are grouped to reflect the maximum simultaneous flow through these interfaces. The NYISO updates the transmission system model annually in accordance with the IRM database schedule in Section 2.2.

Preparation of the transmission system model requires review by the NYISO's Transmission Planning Advisory Subcommittee before it is delivered to the NYSRC for use in IRM studies.

### 3.5.5 Locational Capacity Requirements

The MARS model used in the IRM study provides an assessment of the adequacy of the NYCA transmission system to deliver energy from one zone to another for meeting load requirements. Previous studies have identified transmission constraints between certain load zones that could impact the LOLE of these zones, as well as the statewide LOLE. To minimize these potential LOLE impacts and to ensure that sufficient capacity is available in the constrained zones and that NYSRC Reliability Rules are met, these zones require a minimum portion of their NYCA ICAP requirements (locational capacity requirements) to be electrically located within these zones. Locational capacity requirements are normally expressed as a percentage of each Locality's annual peak load.

In accordance with the NYSRC/NYISO Agreement and the NYISO's tariff, the NYISO is responsible for establishing the final locational capacity requirements. Prior to the NYISO's locational capacity requirement analysis, the NYSRC determines "preliminary" LCRs for Zone J (New York City) and Zone K (Long Island) in conjunction with the IRM calculation process using the methodologies described in Section 3.4.

In addition to determining the final LCRs for Zones J and K, the NYISO sets the LCR for the combined Zones G, H, I, and J Zones (G-J Locality) which it applies to ICAP Market. The NYISO starts the LCR study with the Final IRM established by the NYSRC. Adjustments are made to the NYSRC data base if assumptions, such as the load forecast, are updated. Differences between these databases, if any, are described in an annual NYISO study report in accordance with NYSRC Reliability Rules A.1 and A.2.] Appendix D describes the procedure used by ICS to align, if necessary, the base case to the Final IRM, in preparation for the LCR Study by the NYISO.

Formatted: Not Highlight

### 3.5.6 External Control Area Load and Capacity Models

The reliability of NYCA depends on a large extent on emergency assistance from the external Control Areas with which the NYCA has direct connections to and reserve sharing agreements. These include all of the NPCC Areas (except the Maritimes) and the PJM-RTO. Therefore, load and capacity models of these external Control Areas are represented in the MARS analyses. The load and capacity models for New England, PJM-RTO, Ontario, and Quebec are based on data received directly from these external Control Areas. Another source of external Control Area data is the most current MARS data base used in NPCC studies, provided by NPCC on request. The latest model information available for representation of external areas will be utilized.

The primary consideration for developing the final load and capacity models for the external



## DRAFT – FOR DISCUSSION PURPOSES ONLY

Control Areas is to avoid overdependence on the external Control Areas for emergency capacity support. For this reason, a limit is placed on the amount of emergency capacity support that the NYISO can receive from external Control Areas in the IRM study. The value of this limit is based on a recommendation from the ICS that considers the amount of ten-minute reserves that are available in the external Control Areas above an Area's required reserve, along with other factors.

In addition, an external Control Area's LOLE assumed in the IRM Study cannot be lower than its own LOLE criterion and its reserve margin can be no higher than that external Control Area's minimum requirement. Only if the external Control Area's LOLE is higher than its own criterion while that Control Area's reserve margin is lower than its minimum requirement, its pre-emergency demand response (DR) can be represented. However, EOPs are not represented in external Control Area capacity models. This is because there are uncertainties associated with the performance and availability of these resources and the ability to deliver them to NYCA boundaries during a system emergency event, as well as recognition of other unknowns in the external Control Area modeling representation.

Another consideration for developing models for the external Control Areas is to recognize internal transmission constraints within the external Control Areas that may limit emergency assistance to the NYCA. This recognition is considered either explicitly, or through direct multi-area modeling providing there is adequate data available to accurately model transmission interfaces and load areas within these external Control Areas.

The external Control Area's load shapes would normally match those chosen for the NYCA. A recommendation of selecting differing years should depend on what years are chosen to represent NYCA's load shape, review of the years chosen by NPCC and PJM for their studies, and other factors. The top three summer peak load days of an external Control Area should be specified in the load model to be coincident with the NYCA top three peak load days. The purpose of this is to capture the higher likelihood that there will be considerably less load diversity between the NYCA and external Control Areas on very hot summer days.

### **3.5.7 External Control Area Capacity**

The study models external capacity in a manner that allows the model to utilize emergency assistance from the neighboring control areas to be relied upon as necessary (see section 3.5.6) to meet the LOLE criteria. Only certain grandfathered contracts and External CRIS are explicitly modeled in the study to allow the model to utilize the full amount of emergency assistance that can be made available due to the inter-control area tie capability limits. Once the NYCA IRM and LCRs are set for the Capability Year, the NYISO conducts a separate study utilizing the base case to evaluate whether additional capacity import rights may be made available to external control area resources while preserving the necessary amount of emergency assistance available over the inter-control area ties to maintain the IRM and corresponding LOLE

## **3.6 Sensitivity Analysis**

In addition to running a base case using the input assumptions described in Section 3.5, sensitivity studies are run to determine reserve margin requirement outcomes if using different

## DRAFT – FOR DISCUSSION PURPOSES ONLY

assumptions than in the base case. Sensitivity studies provide a mechanism for illustrating “cause and effect” of how some performance and/or operating parameters and study assumptions can impact reliability. Certain sensitivity studies also serve to inform the NYSRC Executive Committee of how the IRM may be affected by deviations from selected base cases assumptions (see Section 4). Various types of sensitivity studies are grouped as follows:

*MARS Parameter Impacts* – This type of sensitivity study illustrates how MARS evaluations and IRM requirements are impacted by not representing certain modeling parameters within MARS. Examples of these sensitivity studies that could be considered are: NYS transmission system capability not represented, i.e., transmission constraints not represented within NYCA; interconnections to external Control Areas not represented, i.e., no emergency assistance to NYCA; and load forecast uncertainty not represented.

*Assumption Uncertainty Impacts* – This type of sensitivity study illustrates the IRM impacts of recognizing the uncertainty of certain base case assumptions described in Section 3.5. These sensitivity studies are normally represented in pairs of high and low assumption ranges related to selected base case assumptions. Occasionally, sensitivity studies in this group are run when alternatives or disagreement may have existed during preparation of base case input assumptions. Examples of these sensitivity studies that could be considered are: higher and lower external Control Area reserves than represented in the base case, higher and lower EOP performance than represented in the base case, and changes in projected generation additions and retirements. Each sensitivity case is defined by representing a reasonable range of assumptions higher and/or lower than the base case value.

*Impacts of Future System Changes* – This type of sensitivity study is sometimes considered to illustrate the impact of possible system changes that could be expected after the capability period currently being examined. An example of this type of sensitivity would be to examine the IRM impacts of future environmental initiatives.

*Special Sensitivity Case* – All substantive assumption changes following approval of the final base assumptions in early October are combined into a single Special Sensitivity Case (see Table 2-1 and Section 3.5). The Special Sensitivity Case is conducted using a Tan 45 analysis (see Section 3.4.2) for determining an IRM. The Executive Committee may adopt the Special Sensitivity Case as the final base case for the IRM study within the schedule as shown in Table 2-1.

An IRM study’s preliminary base case is used to run sensitivity studies (See Section 3.4).

### 3.7 Data Base Confidentiality

A confidentially agreement is in place to prevent disclosure of market sensitive data and data confidentially. FERC Order 889 Code of Conduct rules apply to NYSRC representatives with access to IRM Data Base. From time to time changes in the confidentially agreement may be made.

### 3.8 Standard Error

Another step in assuring a quality result is to determine whether the standard error is acceptable.

## **DRAFT – FOR DISCUSSION PURPOSES ONLY**

To this end, the MARS model is run for 1,000 iterations. If at the 1,000th iteration the desired standard error of 0.025 of the mean LOLE for calculating the 95% confidence level is not achieved, then increase the number of iterations in increments of 250 until the desired standard error is met or exceeded. If the 0.025 mark is met, the number of iterations for all MARS runs in the current year study is maintained. If the number of iterations has changed from the previous year, the ICS will be notified.

### **3.9 Data Base Quality Assurance**

It is critical that the data base used for IRM studies undergo sufficient review by the NYSRC and NYISO in order to verify its accuracy. To accomplish this objective, the NYSRC process for preparing an IRM study base case utilizes a method for reviewing the data base, while respecting confidentiality issues (see Section 3.7).

The NYISO and General Electric both conduct preliminary data quality assurance reviews as soon as base case assumptions are developed and prior to preparation of a preliminary base case. An additional data review is conducted by the NYISO, General Electric, and transmission owners prior to preparation of the final base case. Masked and encrypted input data is provided by the NYISO to the transmission owners for their reviews. Any data found to be in error by these reviews is corrected before being used in the final base case. Results of quality assurance reviews are reported to ICS. Additional quality assurance reviews are conducted as deemed necessary by ICS.

In addition to above processes to review the IRM base case, the NYISO has its internal processes to evaluate whether the data supplied by Market Participants is consistent with NYISO procedures.

## Section 4: Responsibilities

This section describes the responsibilities for providing and developing input data and modeling assumptions, conducting the NYCA IRM studies, and establishing the required IRM as described in Section 3. There are four entities having such responsibilities: ICS, NYISO, Market Participants, and the NYSRC Executive Committee.

### 4.1 Installed Capacity Subcommittee

The ICS has the overall responsibility of managing studies and preparing reports for establishing NYCA installed capacity requirements. Specific responsibilities include:

- Develop and approve all modeling and database assumptions to be used in the reliability calculation process. These assumptions include load models, representation of NYPA generating units and other types of resource capacity, emergency operating procedures, transmission representation, and external Control Area models (see Section 3.5). Review proposed major modeling enhancements to ensure technical accuracy and implementation meets study schedule requirements.
- Approve the version of the MARS program to be used for the study (see Section 3.2).
- Manage conduct of MARS cases for developing the preliminary and final base cases, including benchmarking requirements.
- Recommend to the Executive Committee the sensitivity studies to be run (see Section 3.6).
- Together with NYISO staff, review and ensure database accuracy (see Section 3.5.7).
- Ensure that the timeline requirements in Section 2.2 are met.
- Arrange for supplemental computer facilities as needed.
- Prepare status updates and the IRM Study Report for NYSRC Executive Committee review.
- Coordinate above activities with NYISO staff.

### 4.2 NYISO

The NYSRC relies on the NYISO to provide sufficient technical and computer support for the IRM Study effort. The basis for this support is provided in the NYISO/NYSRC Agreement. The NYISO leases the MARS computer program used for the reliability calculation studies. The NYISO utilizes the same program and NYSRC assumptions from the IRM Study for its own study of LSE locational capacity requirements.

- Conduct MARS studies for the IRM Study as requested by ICS.
- Develop load, capacity, transmission, and EOP models and supporting data for consideration by ICS for use in the IRM study and report. This information should be provided to ICS so as to allow the timeline requirements in Section 2.2 to be met. The NYISO should make recommendations to ICS concerning the application of these models in the IRM Study. Collaborate with ICS to prepare white papers describing proposed major modeling enhancements.

## DRAFT – FOR DISCUSSION PURPOSES ONLY

- Together with ICS, review and ensure database accuracy. Retain General Electric to assist in this review.
- Benchmark new versions of MARS.
- Obtain technical support for the application of MARS for IRM studies from General Electric, as well as other outside entities, as required.

### 4.3 Market Participants

Market Participants are responsible for providing information concerning load, planned resource capacity changes, and transmission system modeling to the NYISO. Transmission Owner representatives participate in review of database accuracy.

### 4.4 NYSRC Executive Committee

The NYSRC Executive Committee has the responsibility of approving the final IRM requirements for the next capability year.

- Review and approve preliminary and final base case assumptions and models for use in IRM Study.
- Review preliminary base case IRM results.
- Approve sensitivity studies to be run and their results.
- Review and approve the IRM Study prepared by ICS.
- Establish and approve the final NYCA IRM requirement for the next capability year (see Section 5).
- To the extent practicable, ensure that the schedule for the above approvals allow that the timeline requirements in Section 2.2 are met.
- Notify the NYISO of the NYCA IRM requirements and meet with NYISO management as required to review IRM Study results.
- Make IRM Study results available to state and federal regulatory agencies and to the general public by posting the study on the NYSRC Web site.

## Section 5: Establishment of the Final IRM

### 5.1 Consideration of IRM Study Results

The process utilized by the NYSRC Executive Committee for establishing the Final IRM of the following capability year includes consideration of the Final IRM base case study results and the sensitivity studies, based on the procedures and models described in Section 3, as well as other relevant factors. Following a full discussion of the base case study results, the sensitivity studies, and other factors considered by Executive Committee members to be relevant, the Executive Committee proceeds to vote on the Final IRM value. The sensitivity studies serve to inform the Executive Committee of how the base case IRM might be affected, in either direction, by deviations from selected assumptions. The IRM Study represents the Executive Committee's best judgment with respect to the base case assumptions that should be used in developing the base case IRM. The weight, if any, accorded one or more sensitivity studies in establishing a Final IRM will be determined by Executive Committee members based on the relevant circumstances. The Final IRM adopted by the Executive Committee will comply with the NYSRC resource adequacy criterion.

### 5.2 Executive Committee IRM Voting Procedure

#### Step 1. Executive Committee Discussion

Before any vote is taken the Executive Committee will conduct a full discussion of the IRM Study, the base case IRM, and the sensitivity studies, in which the Executive Committee members will have an opportunity to express their views.

#### Step 2 Straw Poll

Following the discussion in Step 1, a secret straw poll will be taken in which each Executive Committee member will indicate the IRM the member supports as the final IRM. The IRMs to be voted on will include the base case IRM and any IRM plus or minus 0.2% above or below the base case IRM. The Executive Secretary will announce the three IRMs that received the most votes.

#### Step 3 IRM Voting

Executive Committee will take successive votes on the IRM choices as determined in Step 2. If the base case IRM is one of the three IRM choices that received the most in the straw poll, then the base case IRM and the other two IRM choices with the most votes in the straw poll will be voted on. However, the base case IRM will always be included among the IRM choices to be voted on. The Executive Secretary will distribute printed ballots for each vote which will indicate the subject of the vote, the identity of the Executive Committee member voting, and the member's vote. The Executive Secretary will tabulate the votes which will be confirmed by the NYSRC Counsel. The Executive Secretary will announce the results but not how individual Executive Committee members

voted. The Executive Secretary and the Counsel will treat the votes by individual Executive Committee members as confidential and not to be disclosed to any other Executive Committee member or any other party except on the express direction of the Executive Committee. The Executive Secretary will retain the voting records for a period of three years. If one of the IRM options voted on receives the necessary nine affirmative votes, the voting will be concluded.

**Step 4: Executive Committee Caucus**

If none of the choices voted on in Step 3 receives the necessary nine affirmative votes, the Executive Committee will caucus to discuss options for achieving the necessary nine affirmative votes.

**Step 5: Subsequent IRM Voting**

Following the Executive Committee caucus, the Executive Committee will vote again on the IRM choices that were voted on in Step 3.

**Step 6: Final Resolution**

If none of the IRM options voted on in Step 5 receives the necessary nine affirmative votes, Steps 4 and 5 will be repeated until an IRM receives the necessary nine affirmative votes.

**5.2**

1. ~~The Executive Committee will conduct a full discussion of the IRM Study, the base case IRM, and the sensitivity studies, in which the Executive Committee members will have an opportunity to express their views.~~

2. ~~Following the discussion of the IRM Study, the base case IRM, and the sensitivity studies, a secret straw poll will be taken in which each Executive Committee member will indicate the IRM the member supports as the final IRM based on the discussion of the IRM Study, the base case IRM, and the sensitivity studies. Recommended IRMs different from the base case IRM will be expressed in increments higher or lower than the base case IRM rounded to the nearest whole or half integer. The Executive Secretary will announce only the IRM that received the most votes. The Executive Committee will then vote on the IRM that received the most votes in the straw poll. If the nine votes necessary to approved are not received, a vote will be taken on the IRM that received the second most votes, and so on.~~

3. ~~If there is a tie in the straw poll, the IRM first voted on will be the IRM that is closest to the base case IRM. If the IRMs are equally close to the base case IRM, the IRM that is closest to the current IRM will be voted on first. If the IRMs are equally close to the base case IRM and the current IRM, the Executive Secretary will announce a tie vote and the IRMs receiving the highest number of votes, and request a new secret straw poll to break the tie. If the tie is not broken, the Chairman will decide which IRM will be voted on first.~~

**Formatted:** Normal, Left, Right: 0", No bullets or numbering, Allow hanging punctuation, Tab stops: Not at 0.46"

**Formatted:** Font: 13 pt

**Formatted:** Body Text, Justified, Indent: Left: 0.32", Right: 0.08", Space Before: 0 pt, Line spacing: single, Outline numbered + Level: 3 + Numbering Style: 1, 2, 3, ... + Start at: 1 + Alignment: Left + Aligned at: -0.25" + Indent at: 0", Tab stops: 0.57", Left

**Formatted:** No bullets or numbering

**Formatted:** Font: 13 pt

**Formatted:** Body Text, Justified, Indent: Left: 0.32", Right: 0.08", Space Before: 0 pt, Line spacing: single, Outline numbered + Level: 3 + Numbering Style: 1, 2, 3, ... + Start at: 1 + Alignment: Left + Aligned at: -0.25" + Indent at: 0", Tab stops: 0.57", Left

DRAFT – FOR DISCUSSION PURPOSES ONLY

~~4. The Executive Secretary will distribute printed ballots for each vote which will indicate the subject of the vote, the identity of the Executive Committee member voting, and the member's vote. The Executive Secretary will tabulate the votes and announce the results, but not how individual Executive Committee members voted. The tabulation of the vote will be confirmed by the Counsel to the NYSRC. The Executive Secretary and the Counsel will treat the votes by individual Executive Committee members as confidential information not to be disclosed to any Executive Committee member or any other party, except on the express direction of the Executive Committee. The Executive Secretary will retain the voting records for a period of three years.~~

Formatted: No bullets or numbering

~~5. Once an IRM has achieved the votes needed for approval, a secret confirmation vote may be held at the request of an Executive Committee member.~~

Formatted: Font: 13 pt

Formatted: Body Text, Justified, Right: 0.08", Space Before: 0 pt, Line spacing: single, Outline numbered + Level: 3 + Numbering Style: 1, 2, 3, ... + Start at: 1 + Alignment: Left + Aligned at: -0.25" + Indent at: 0", Tab stops: 0.57", Left

~~6. Once approved by the Executive Committee, an IRM will remain in effect until a subsequent IRM is approved by the Executive Committee. Consequently, should the Executive Committee not adopt a Final IRM for a particular capability year, the IRM currently in effect will remain in effect for that capability year.~~

Formatted: No bullets or numbering

Formatted: Indent: Left: 0.57", No bullets or numbering



## APPENDIX A: Unified Methodology Description

### 1.0 Introduction

Appendix A describes a procedure to develop the statewide Installed Reserve Margin (IRM) versus Minimum Locational Capacity Requirements (LCRs) curves.

Within the New York Control Area (NYCA) there are currently two zones identified as localities to which this procedure would apply. They are the New York City and Long Island zones.

### 2.0 Initial Conditions

- 2.1. A Multi-Area Reliability Simulation (MARS) base case database exists for the upcoming capability year.
- 2.2. Localities in the NYCA that require minimum LCR have been identified (in Section 1).
- 2.3. Any capacities that have been shifted, removed, or added to arrive at the base case for the IRM study should be reset to the “as found” case before initiating this procedure. This procedure should start with the forecast capacities, and forecast loads.

### 3.0 Setting up the base case model for a desired study reserve margin (SRM)

Installed capacity (ICAP) is either added to or removed from zones west of the Total East Interface that have excess capacity reserves (capacity rich zones) so that the statewide capacity to peak load ratio equals the desired study reserve margin (SRM) point.

- 3.1. A portion of this installed capacity (ICAP) is added to or removed from each capacity rich zone. The amount to be added to or removed from each capacity rich zone is based on the ratio of its excess unforced capacity (UCAP) to the total excess unforced capacity (UCAP) of all capacity rich zones.
- 3.2. Capacity removal or addition is achieved by adjusting the respective entry for each capacity rich zone in the MOD-MDMW table of the MARS program. The amount entered in the table is the equivalent UCAP amount for the amount of ICAP to be removed or added. UCAP for a zone is equal to the ICAP for that zone times one minus the weighted equivalent forced outage rate (1-EFOR) for the zone.
- 3.3. The correct amount of ICAP added to or removed from NYCA should be verified by performing a single iteration MARS run using the capacity adjusted model, checking the total capacity from the MARS 07 output file, and calculating the achieved reserve margin.

## DRAFT – FOR DISCUSSION PURPOSES ONLY

- 3.4. Run the MARS model for 1,000 iterations. If at the 1000th iteration the desired standard error of 0.025 of the mean LOLE for calculating the 95% confidence level is not achieved, the NYISO will notify the ICS and then increase the number of iterations in increments 250 until the desired standard error is met or exceeded.

### 4.0 Determination of the initial target capacity for each locality

The initial target capacity for a locality is the maximum capacity that is shifted from or to the locality to yield a NYCA LOLE risk of 0.1 days/year, while all other zones and localities remain unchanged.

- 4.1. Using the capacity adjusted base case from Section 3 as the base model, if the LOLE for the base case is less or greater than 0.1 days/year, remove or add respectively a trial amount of ICAP from or to the locality being considered.
- 4.2. The equivalent UCAP amount to be added to or removed from the locality is entered in the respective entry for the locality in the MOD-MDMW table of the MARS program.
- 4.3. To maintain the same desired reserve margin, the same ICAP amount should be removed from or added to the capacity rich zones using the steps in Section 3.0.
- 4.4. Run a MARS simulation until the standard error of the LOLE index is less than or equal to 0.025 or when the maximum number of replications has been reached.
- 4.5. If the NYCA LOLE is below or above 0.1 days/year, repeat Sections 4.1 to 4.4 with a higher or lower trial amount of ICAP until the NYCA LOLE reaches 0.1 days/year or within an acceptable range.
- 4.6. Record the total amount of ICAP added to or removed from the locality being considered. This is the initial target capacity for the locality.
- 4.7. If a NYCA LOLE of 0.1 days/year cannot be achieved either by shifting capacity to or from the locality, the desired SRM is not achievable and a new SRM should be selected and repeat steps in Section 3.
- 4.8. If a NYCA LOLE of 0.1 days/year is achieved for the locality, repeat the steps in Sections 4.1 to 4.7 for each identified locality and record the amount of ICAP capacity shift for each of these localities. These are the initial target capacities for the zones. (Before considering a new locality, reset the model to the original capacity adjusted base case, i.e. with the desired reserve margin, as described in Section 3.0)

### 5.0 Determination of the capacity multiplier for each locality

The capacity multiplier for an identified locality is the initial target capacity for the locality, obtained in Section 4, divided by the sum of the initial target capacities for all the identified localities. These multipliers determine the portion of the total installed capacities to be shifted for each identified locality. For example, if zones 1 and 2 are the only two localities identified, and the initial target capacities for zones 1 and 2 are 300 MW and 100 MW, respectively, then the capacity multiplier for zone 1 would be  $300/400$  or 0.75,

## DRAFT – FOR DISCUSSION PURPOSES ONLY

while the capacity multiplier for zone 2 would be 100/400 or 0.25.

### 6.0 Determination of the actual capacity removal or addition for each locality

- 6.1. Based on the initial LOLE risk for the capacity adjusted based model obtained in Section 3, estimate a total trial amount of ICAP to be shifted from or to the identified localities.
- 6.2. This trial amount of capacity will be shifted from or to the identified localities using the capacity multipliers obtained in Section 5.0. For example, using the example in Section 5.0, if 1000 MW is to be removed from zones 1 and 2, then the amount of ICAP to be removed from zone 1 would be  $1000 * 0.75$  or 750 MW, and for zone 2, 250 MW respectively.
- 6.3. The equivalent amount of UCAP for each identified locality is then entered into the respective entries in the MOD-MDMW table of the MARS program.
- 6.4. To maintain the desired SRM, the same amount of ICAP capacity must be shifted to or from the capacity rich zones. The amount of equivalent UCAP entries for each of the capacity rich zones in the MOD-MDMW table can be determined using the same steps described in Section 3.
- 6.5. Run a MARS simulation until the standard error of the LOLE index is less than or equal to 0.025 or when the maximum number of replications has been reached. Record the NYCA LOLE risk.
- 6.6. If the NYCA LOLE risk is below or above 0.1 days/year, increase or decrease the trial amount of ICAP to be shifted from or to the identified localities. Repeat Sections 6.2 to 6.5 until the NYCA LOLE reaches 0.1 days/year or within an acceptable range.
- 6.7. Record the amount of ICAP shifted from or to each identified locality. The remaining amount of ICAP in each identified locality is the total generation in the locality, minus or plus the amount shifted for that locality.

### 7.0 The locational capacity requirement (LCR) for each identified locality

The locational capacity requirement (LCR) for the desired SRM for each identified locality is the ratio, expressed as a percentage, of the remaining amount of ICAP in each identified locality, obtained in Section 6.7, to the forecast peak load of the locality.

### 8.1 Determination of the LCR-IRM curves

Repeat Sections 3.0 to 7.0 to provide the resulting LCRs for a range of desired reserve margins. The results will be used to plot the LCR-IRM curves and determine the desired NYCA LCR-IRM as described in Appendix B.

**APPENDIX B: IRM Anchoring Method**

The IRM Anchoring Method identifies the NYCA IRM Requirements and related MLCR from IRM/LCR curves established by the Unified Methodology. The *anchor point* on the curve is selected by applying a tangent of 45 degrees (“Tan 45”) analysis at the bend (or “knee”) of the curve as shown on Figure B-1 below. Based on these curves, extreme points on the curve on either side of the Tan 45 point may create disproportionate changes in LCR and IRM, since small changes in LCR can introduce larger changes in IRM Requirements and vice versa. A regression analysis is utilized to best fit the IRM/LCR curves and determine the Tan 45 point, rather than a visual inspection of the curves.

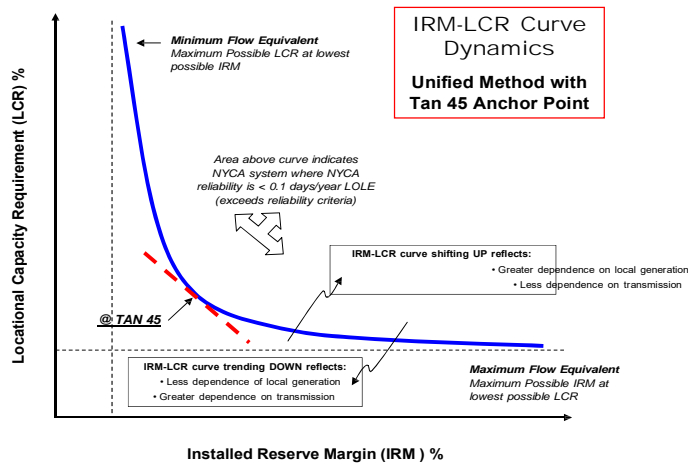

**Figure B-1: IRM-LCR Unified Method Curve Dynamics with Tan 45 Anchor Point**

The IRM/LCR characteristic consists of a curve function, “a knee of the curve” and straight line segments at the asymptotes. The curve function is represented by a quadratic (second order) curve which is the basis for the Tan 45 inflection point calculation. Inclusion of IRM/LCR point pairs remote to the “knee of the curve” may impact the calculation of the quadratic curve function used for the Tan 45 calculation.

## DRAFT – FOR DISCUSSION PURPOSES ONLY

The procedure for determining the best fit curve function used for the calculation of the Tan 45 inflection point to define the base case requirement is based on the following methodology:

- 1) Start with all points on IRM/LCR Characteristic.
- 2) Develop regression curve equations for all different point to point segments consisting of at least four consecutive points.
- 3) Rank all the regression curve equations based on the following:
  - Sort regression equations with highest  $R^2$ .
  - Remove any equations which show a negative coefficient in the first term. This is the constant labeled 'a' in the quadratic equation:  $ax^2+bx+c$
  - Ensure calculated IRM is within the selected point pair range, i.e., if the curve fit was developed between 14% and 18% and the calculated IRM is 13.9%, the calculation is invalid.
  - In addition, there must be at least one statewide reserve margin point to the left and right of the calculated tan 45 point
  - Ensure the calculated IRM and corresponding LCR do not violate the 0.1 LOLE criteria.
  - Check results to ensure they are consistent with visual inspection methodology used in past years studies.

This approach identifies the quadratic curve functions with highest  $R^2$  correlations as the basis for the Tan 45 calculation. The final IRM is obtained by averaging the Tan 45 IRM points of the NYC and LI curves. The Tan 45 points are determined by solving for the first derivatives of each of the “best fit” quadratic functions as a slope of -1. Lastly, the resulting MLCR values are identified.

**APPENDIX C: Alignment Process**  
**Procedure for Aligning the Base Case IRM to the Final IRM in Preparation**  
**for the Locational Capacity Requirement Study by the NYISO**

The IRM base case model is used as the foundation for establishing the IRM, the Locational Capacity Requirements (LCRs), and for certain other NYISO reliability studies. Appendix D discusses the potential changes to the IRM base case model needed by the NYISO to conduct various NYISO studies, including the LCR Study.

**Establishing Final IRMs above the Study’s Base Case Results**

When the NYSRC Executive Committee establishes a final IRM that is higher than the IRM study’s base case result, it is adding an IRM margin to the base case results. The purpose of this margin is to ensure, considering base case assumption uncertainties, that the NYSRC resource adequacy Loss of Load Expectation (LOLE) criterion is met at the final IRM level. NYISO studies maintain this margin in using the IRM data base for calculating and setting the LCRs and External Capacity Rights.

**Establishing Final IRMs below the Study’s Base Case Results**

When the NYSRC Executive Committee establishes a final IRM that is lower than the base case IRM – after weighing consideration of sensitivity studies and other factors – it is confident that this lower IRM will meet the NYSRC resource adequacy criterion.

It is understood that in establishing LCRs the NYISO will calculate LCR values, that together with the final IRM, will meet the NYSRC 0.100 LOLE criterion. Since the introduction of a lower IRM into the study’s base case data base could result in a LOLE above the criterion, the data base is adjusted so as to maintain the 0.100 days/year LOLE criterion. This adjustment is accomplished by adding an adjustment step in the EOP table prior to load shedding. The number of MWs added to the adjustment step is prorated across all zones consistent with the zone’s peak load forecast for the upcoming Capability Year, and set at a total level that causes the base case result to meet the LOLE criterion for the Final IRM that has been approved by the NYSRC Executive Committee.

After completion of the above base case alignment analysis, the NYISO will prepare a report for ICS review. This report shall state the amount of (UCAP) MWs added to each zone, the zonal LOLE values before and after the adjustment, the resulting NYCA LOLE and the MLCRs at the established IRM.

The aligned base case database is used by the NYISO as a reference for their studies.

**APPENDIX D: EFORD**  
**Development of Generator Transition Rate Matrices**  
**For MARS that are Consistent with the EFORD Reliability Index**