

NYSRC Reliability Rules (Possible Design Gap)

Existing Breaker-and-a-Half Substation

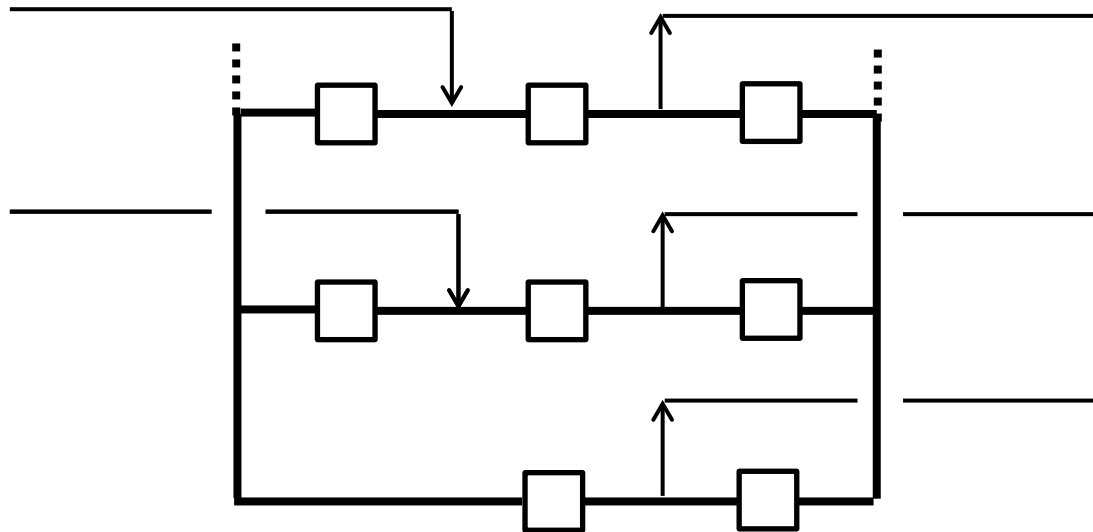

Breaker-and-a-Half Substation with a New Interconnection

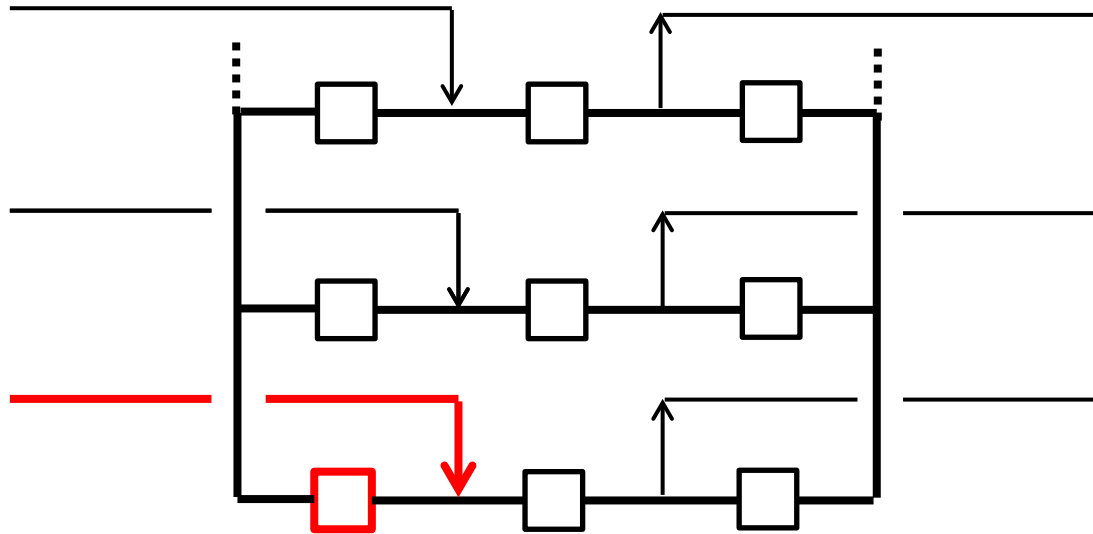

First Contingency (N-1):
Table B-1 Category I (Single Event);
Contingency Event 2
(Opening of any Circuit Breaker)

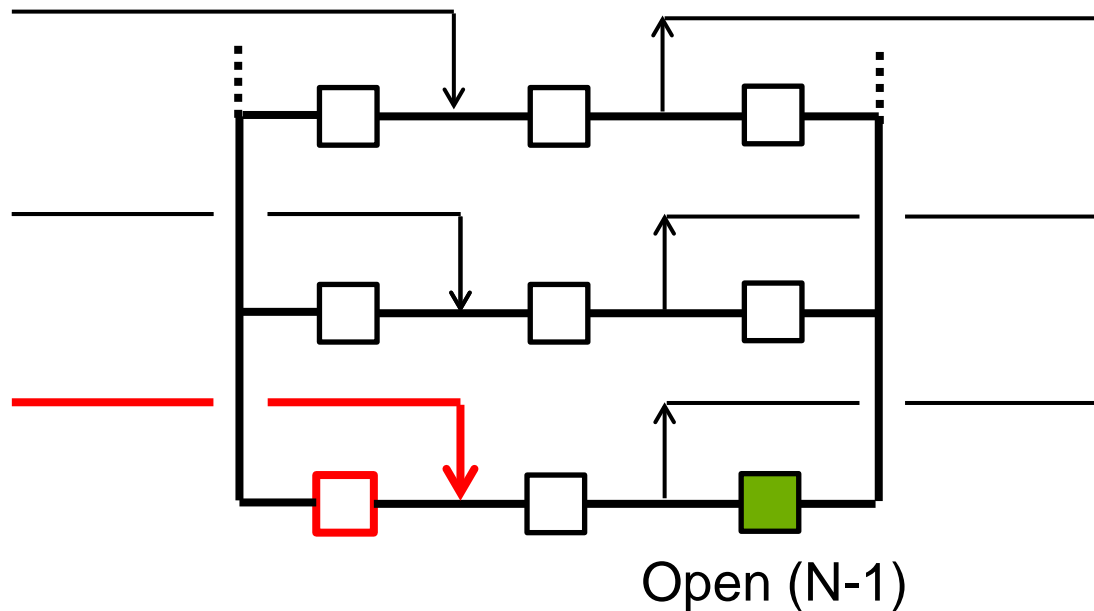

2nd Contingency (N-1/-1) (open 2nd breaker)

Not a Proper N-1/-1 under NYSRC
Reliability Rules Table B-1 Category II

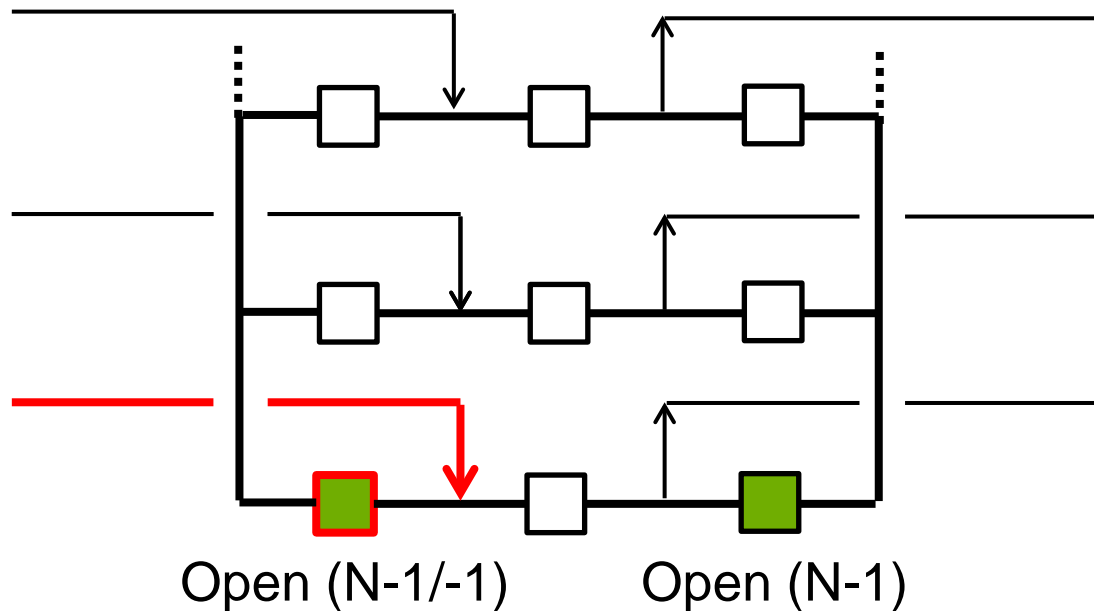

2nd Contingency (N-1/-1) (open 2nd breaker)

Not a Proper N-1/-1 under NYSRC Reliability Rules Table B-1 Category II

