

# Sensitivity - B&C lines out\* - 2019 IRM Preliminary Topology (Summer Limits)

June 22, 2018

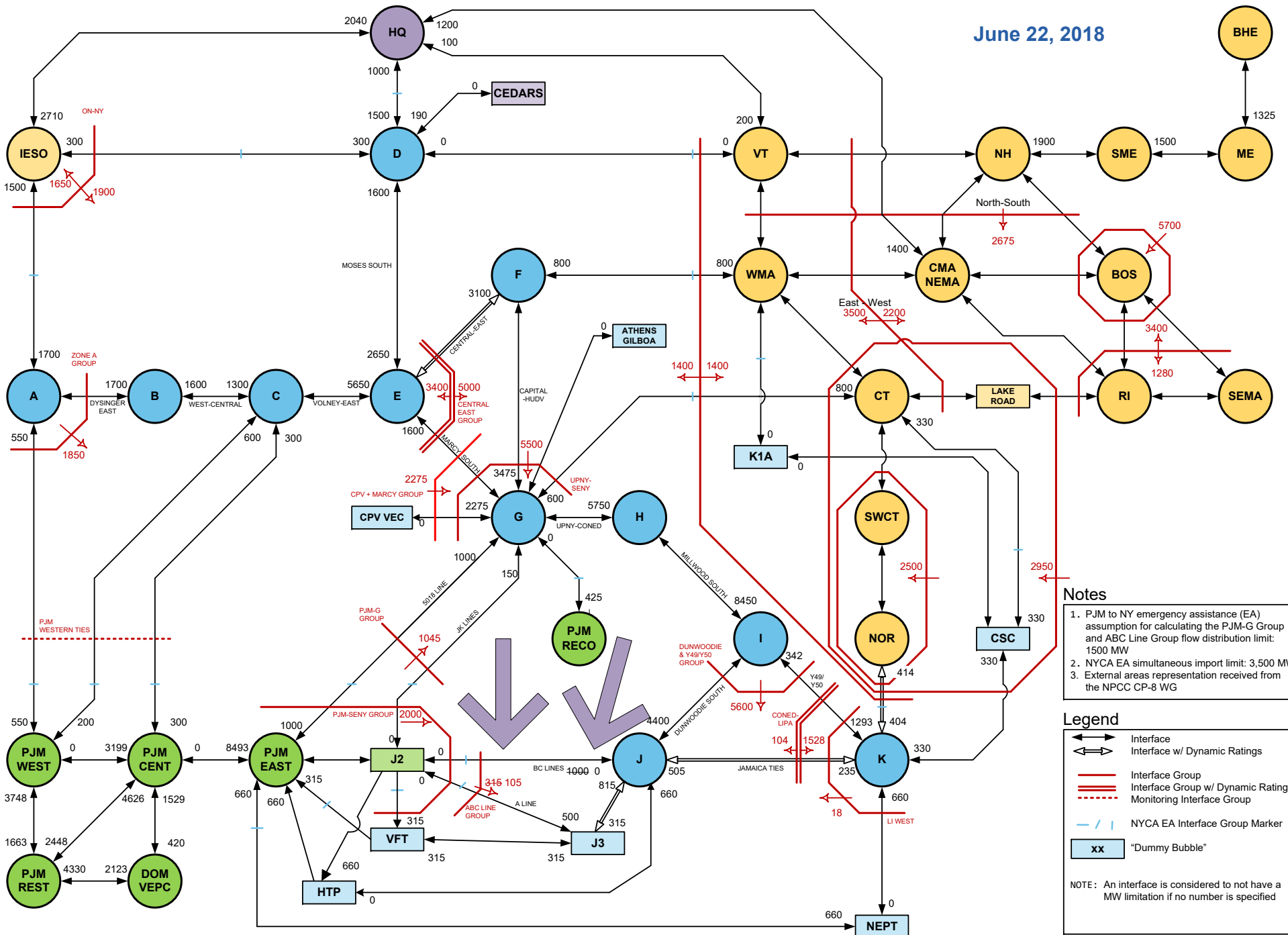

- Notes**
1. PJM to NY emergency assistance (EA) assumption for calculating the PJM-G Group and ABC Line Group flow distribution limit: 1500 MW
  2. NYCA EA simultaneous import limit: 3,500 MW
  3. External areas representation received from the NPCC CP-8 WG

**Legend**

- ↔ Interface
- ↔ Interface w/ Dynamic Ratings
- Interface Group
- Interface Group w/ Dynamic Ratings
- - - Monitoring Interface Group
- / - NYCA EA Interface Group Marker
- xx "Dummy Bubble"

NOTE: An interface is considered to not have a MW limitation if no number is specified

\*This is a simplified representation of the system with zero tie capability over the B&C lines into New York

# 2018 MARS Topology - Dynamic Limits and Grouping Information

September 28, 2017

Interface Group	Limit	Flow Equation
UPNYSENY	5,500	$F_{to\_G} + E_{to\_G} - HUDV\_NE + 1.5*ATHENS\_G + 0.3*CPVVEC\_G$
E2G_CPV	2,275	$E_{to\_G} + 0.9*CPVVEC\_G$
LI_WEST	18	$K_{to\_I\&J} - 0.13*K\_NEPT$

## Central East Voltage Limits, Oswego Complex Units

Depends On:	9MILP1, 9MILP2, FPNUC1, STHIND, OS05, OS06			
Units Available	E_to_F		E_to_FG	
	Fwd	Rev	Fwd	Rev
6	3,100	1,999	5,000	3,400
5	3,050	1,999	4,925	3,400
4	2,990	1,999	4,840	3,400
3	2,885	1,999	4,685	3,400
2	2,770	1,999	4,510	3,400
Otherwise:	2,645	1,999	4,310	3,400

## Staten Island Import Limits, AK and Linden CoGen Units

Unit Availability				J_to_J3	
AK02	AK03	LINCOG1	LINCOG2	Fwd	Rev
A	A	A	A	315	200
U	A	A	A	315	500
A	U	A	A	315	700
A	A	U	A	315	500
A	A	A	U	315	500
Otherwise:				315	815

## Long Island Import Limits, Northport

Depends On:	NPRTG1, NPRTS1-4	
Units Available	LI_NE	
	Norwalk to K	K to Norwalk
5	260	414
Otherwise:	404	414

## Long Island Import Limits, Barret Steam Units

Depends On:	BARS01, BARS02			
Units Available	Jamaica Ties		ConEd-LIPA	
	J to K	K to J	IJ to K	K to IJ
2	235	505	1,528	104
1	235	390	1,528	74
0	235	236	1,528	0

PJM-NY JOA Flow Distribution (Jan 31, 2017 filing)	RECO Load Deliveries	PJM-NY Emergency Assistance
PJM-NY Western Ties	20%	32%
5018 Line	80%	32%
JK Lines	0%	15%
A Line	0%	7%
BC Lines	0%	14%