

# 2019-2020 NYCA IRM Requirement Study

## Final Base Case (FBC) Model Assumptions

Formatted: Font: 26 pt

Assumption Matrix

Draft Version (V4.~~0~~1)

October 3, 2018

### Load Parameters

#	Parameter	2018 Model Assumptions	2019 Model Assumptions	Basis for Recommendation	Model Change	Est. IRM Impact*
1	Peak Load Forecast (Preliminary Base Case – Parametric & Sensitivities )	2017 Gold Book NYCA: 33,078 MW NYC: 11,707 MW LI: 5,305 MW G-J: 16,070 MW	2018 Gold Book NYCA: 32,857MW NYC: 11,474 MW LI: 5,323 MW G-J: 15,815 MW	Most recent Gold Book Forecast is used for Preliminary Base Case parametric study and sensitivity cases	N	Low(-)
2	Peak Load Forecast (Final Base Case)	October 2017 Fcst. NYCA: 32,868 MW NYC: 11,541 MW LI: 5,445 MW G-J: 15,890 MW	October 2018 Fcst. NYCA: xx,xxx MW NYC: yy,yyy MW LI: z,zzz MW G-J: ww,www MW	Forecast based on examination of 2018 weather normalized peaks. Top three external Area peak days aligned with NYCA	N	
3	Load Shape (Multiple Load Shape)	Bin 1: 2006 Bin 2: 2002 Bins 3-7: 2007	Bin 1: 2006 Bin 2: 2002 Bins 3-7: 2007	ICS Recommendation	N	None
4	Load Forecast Uncertainty	Zonal Model to reflect current data with input from Con Ed and LIPA. (Attachment A)	Zonal Model to reflect current data with input from Con Ed and LIPA. (Attachment A)	No Change from 2108 IRM. Based on TO and NYISO data and analyses.	N	None

\*(-) indicates a reduction in IRM while (+) indicates an increase. Range: Low < 0.5%, Medium 0.5% - 1%, High > 1%, Minimal indicates there may be some movement but within 0 to +/- 0.1%.

### Generation Parameters

#	Parameter	2018 Model Assumptions	2019 Model Assumptions	Basis for Recommendation	Model Change	Est. IRM Impact*
1	Existing Generating Unit Capacities	2017 Gold Book values. Use min (DMNC vs. CRIS) capacity value	2018 Gold Book values. Use min (DMNC vs. CRIS) capacity value	Latest Gold Book publication	N	Minimal
2	Proposed New Units (Non-Renewable) and re-ratings	784 MW of new non-wind resources, plus 52 MW of project related re-ratings. (Attachment B1)	MW 11.1 MW of new non-wind resources, plus 209.3 MW of project related re-ratings. (Attachment B1)	Latest Gold Book publication, NYISO interconnection queue, and generator notifications	N	Low(-)
3	Retirements, Mothballed units, and ICAP ineligible units	0 MW retirements or mothballs reported or Units in IIFO and IR (Attachment B2)	0 MW of retirements, 399.2 MW of unit deactivations, and 389.4 MW of IIFO and IR <sup>1</sup> (Attachment B2)	Latest Gold Book publication and generator notifications	N	Low(+)
4	Forced and Partial Outage Rates	Five-year (2012-2016) GADS data for each unit represented. Those units with less than five years – use representative data. (Attachments C and C1)	Five-year (2013-2017) GADS data for each unit represented. Those units with less than five years – use representative data. (Attachments C and C1)	Transition Rates representing the Equivalent Forced Outage Rates (EFORd) during demand periods over the most recent five-year period	N	Minimal
5	Planned Outages	Based on schedules received by the NYISO and adjusted for history	Based on schedules received by the NYISO and adjusted for history	Updated schedules	N	None

<sup>1</sup> ICAP Ineligible Forced Outage (IIFO) and inactive Reserve (IR)

#	Parameter	2018 Model Assumptions	2019 Model Assumptions	Basis for Recommendation	Model Change	Est. IRM Impact*
6	Summer Maintenance	Nominal 50 MWs – divided equally between zones J and K	Nominal 50 MWs – divided equally between zones J and K	Review of most recent data	N	None
7	Combustion Turbine Derates	Derate based on temperature correction curves provided	Derate based on temperature correction curves provided	Operational history indicates the derates are in-line with manufacturer’s curves	N	None
8	Existing and Proposed New Wind Units	77.7 MW of Wind Capacity additions totaling 1733.4 MW of qualifying wind (Attachment B3)	158.3 MW of Wind Capacity additions totaling 1891.7 MW of qualifying wind (Attachment B3)	ICAP units based on RPS agreements, interconnection queue, and ICS input.	N	Low (+)
9	Wind Shape	Actual hourly plant output over the period 2012-2016. New units will use zonal hourly averages or nearby units.	Actual hourly plant output over the period 2013-2017. New units will use zonal hourly averages or nearby units.	Program randomly selects a wind shape of hourly production from the most recent five-year period for each model iteration.	N	Minimal
10	Solar Resources (Grid connected)	Total of 31.5 MW of qualifying Solar Capacity. (Attachment B3)	Total of 31.5 MW of qualifying Solar Capacity. (Attachment B3)	ICAP Resources connected to Bulk Electric System	N	None
11	Solar Shape	Actual hourly plant output over the period 2012-2016. New units will use zonal hourly averages or nearby units.	Actual hourly plant output over the period 2013-2017. New units will use zonal hourly averages or nearby units.	Program randomly selects a solar shape of hourly production from the most recent five-year period for each model iteration.	N	Minimal

#	Parameter	2018 Model Assumptions	2019 Model Assumptions	Basis for Recommendation	Model Change	Est. IRM Impact*
12	BTM- NG Program	Change Stony Brook to its full 47 MW output (formerly modeled at 9.6 MW net of host load).  Forecast Load adjusted to account for exposure of host load.  (Attachment B4)	<del>No Additions</del> <u>Addition of Greenidge 4 to BTM NG program. 104.3 MW unit.</u>  <u>Forecast load adjustment of 11.6 MW (Attachment B4)</u>	Both the generation of the participating resources and the full <del>(former)</del> host loads <u>are</u> modeled.	N	<del>None</del> <u>Minimal</u>
13	Small Hydro Resources	Derate by 46%	Actual hourly plant output over the period 2013-2017.	Program randomly selects a Hydro shape of hourly production from the most recent five-year period for each model iteration.	N	Minimal
14	Large Hydro	Probabilistic Model based on 5 years of GADS data	Probabilistic Model based on 5 years of GADS data (2013-2017)	Transition Rates representing the Equivalent Forced Outage Rates (EFORd) during demand periods over the most recent five-year period	N	Minimal
15	Land Fill Gas	Derates based on Capacity Factors	Actual hourly plant output over the period 2013-2017.	Program randomly selects a LFG shape of hourly production from the most recent five-year period for each model iteration.	Y	Minimal

### Transactions – Imports and Exports

#	Parameter	2018 Model Assumptions	2019 Model Assumptions	Basis for Recommendation	Model Change	Est. IRM Impact*
1	Capacity Purchases	Existing Rights: PJM – 1080 MW HQ – 1110 MW All contracts model as equivalent contracts	Existing Rights: PJM – 1080 MW HQ – 1110 MW All contracts model as equivalent contracts	Grandfathered Rights, ETCNL, and other awarded long-term rights.	N	None
2	Capacity Sales	Long Term firm sales Summer 283.8 MW	Long Term firm sales Summer 279.3 MW	These are long term federal contracts.	N	None
3	FCM Sales from a Locality <sup>2</sup>	No Sales within study period	No Sales modeled within study period	White Paper, NYISO recommendation, and ICS discussions	N	NA
4	New UDRs	No new UDR projects	No new UDR projects	Existing UDR elections are made by August 1 <sup>st</sup> and will be incorporated into the model.	N	NA

<sup>2</sup> Final FCM sales that will materialize are unknowable at the time of the IRM study. To reflect the impact these sales have on reliability, the NYISO applies a Locality Exchange Factor in the market.

## Topology

#	Parameter	2018 Model Assumptions	2019 Model Assumptions	Basis for Recommendation	Model Change	Est. IRM Impact*
1	Interface Limits	All changes reviewed and commented on by TPAS	Update provided to TPAS with updated VFT return path. <u>B and C lines out of service for base case. Par 33 from Ontario out of service.</u> (Attachment E)	Based on the most recent NYISO studies and processes, such as Operating Study, Operations Engineering Voltage Studies, Comprehensive System Planning Process, and additional analysis including interregional planning initiatives.	N	<del>Minimal</del> Low (+)
2	New Transmission	None Identified	None Identified	Based on TO provided models and NYISO's review.	N	NA
3	AC Cable Forced Outage Rates	All existing Cable EFORs updated for NYC and LI to reflect most recent five-year history (2012-2016)	All existing Cable EFORs will be updated for NYC and LI to reflect most recent five-year history (2013-2017)	TO provided transition rates with NYISO review.	N	Minimal
4	UDR Line Unavailability	Five year history of forced outages(2012-2016)	Five year history of forced outages (2013-2017)	NYISO/TO review.	N	Minimal

## Emergency Operating Procedures

#	Parameter	2018 Model Assumptions	2019 Model Assumptions	Basis for Recommendation	Model Change	Est. IRM Impact*
1	Special Case Resources	July 2017 –1219 MW based on registrations and modeled as 868 MW of effective capacity. Monthly variation based on historical experience*	July 2018 –1309 MW based on registrations and modeled as <del>933</del> <u>903</u> MW of effective capacity. Monthly variation based on historical experience*	SCRs sold for the program discounted to historic availability. Summer values calculated from July 2018 registrations. Performance calculation updated per ICS presentations on SCR performance.  (Attachment F)	N	Minimal
2	EDRP Resources	July 2017 16 MW registered modeled as 3 MW in July and proportional to monthly peak load in other months. Limit to five calls per month	July 2018 5.5 MW registered modeled as 1.0 MW in July and proportional to monthly peak load in other months. Limit to five calls per month	Those sold for the program discounted to historic availability. Summer values calculated from July registrations and forecast growth.	N	Minimal
3	Other EOPs	609.6 MW of non-SCR/non-EDRP resources	Ccc MW of non-SCR/non-EDRP resources  (Attachment D)	Based on TO information, measured data, and NYISO forecasts.	N	Minimal

\* The number of SCR calls is limited to 5/month when calculating LOLE based on all 8,760 hours.



### External Control Areas

#	Parameter	2018 Model Assumptions	2019 Model Assumptions	Basis for Recommendation	Model Change	Est. IRM Impact*
1	PJM	Load and Capacity data provided by PJM/NPCC CP-8 Data may be adjusted per NYSRC Policy 5	Load and Capacity data provided by PJM/NPCC CP-8 Data may be adjusted per NYSRC Policy 5 (Attachment E)	Initial review performed by the NPCC CP-8 WG prior to Policy 5 changes.	N	
2	ISONE, Quebec, IESO	Load and Capacity data provided by ISONE/NPCC CP-8 Data may be adjusted per NYSRC Policy 5	Load and Capacity data provided by ISONE/NPCC CP-8 Data may be adjusted per NYSRC Policy 5 (Attachment E)	Initial review performed by the NPCC CP-8 WG prior to Policy 5 changes.	N	
5	Reserve Sharing	All NPCC Control Areas indicate that they will share reserves equally among all members and then among non-members	All NPCC Control Areas indicate that they will initially share reserves equally among all members and then among non-members	Per NPCC CP-8 WG.	N	NA
6	Emergency Assistance	Statewide Limit of 3,500 MW of emergency assistance allowed from neighbors.	Statewide Limit of 3,500 MW of emergency assistance allowed from neighbors.	White paper on Modelling of Emergency Assistance for NYCA in IRM studies	N	None

Miscellaneous

#	Parameter	2018 Model Assumptions	2019 Model Assumptions	Basis for Recommendation	Model Change	Est. IRM Impact*
1	MARS Model Version	Version 3.21.9	Version 3.22.6	Per benchmark testing and ICS recommendation.	N	None
2	Environmental Initiatives	No estimated impacts based on review of existing rules and retirement trends	No estimated impacts based on review of existing rules and retirement trends	Review of existing regulations and rules.	N	None

DRAFT

# Attachment A

## NYCA Load Forecast Uncertainty Model

### 2018 and 2019 LFU Models

2019 Model is Unchanged from 2018

2018 Load Forecast Uncertainty Models						
Step	Multiplier	Zones A-E	Zones F&G	Zones H&I	Con Ed (J)	LIPA (K)
1	0.0062	0.8431	0.8067	0.7978	0.8388	0.7659
2	0.0606	0.8944	0.8674	0.8624	0.8887	0.8351
3	0.2417	0.9474	0.9303	0.9249	0.9371	0.9175
4	0.3830	1.0000	0.9933	0.9817	0.9821	1.0000
5	0.2417	1.0502	1.0541	1.0293	1.0219	1.0695
6	0.0606	1.0959	1.1107	1.0639	1.0547	1.1206
7	0.0062	1.1351	1.1608	1.0822	1.0786	1.1586

2019 Load Forecast Uncertainty Models						
Step	Multiplier	Zones A-E	Zones F&G	Zones H&I	Con Ed (J)	LIPA (K)
1	0.0062	0.8431	0.8067	0.7978	0.8388	0.7659
2	0.0606	0.8944	0.8674	0.8624	0.8887	0.8351
3	0.2417	0.9474	0.9303	0.9249	0.9371	0.9175
4	0.3830	1.0000	0.9933	0.9817	0.9821	1.0000
5	0.2417	1.0502	1.0541	1.0293	1.0219	1.0695
6	0.0606	1.0959	1.1107	1.0639	1.0547	1.1206
7	0.0062	1.1351	1.1608	1.0822	1.0786	1.1586

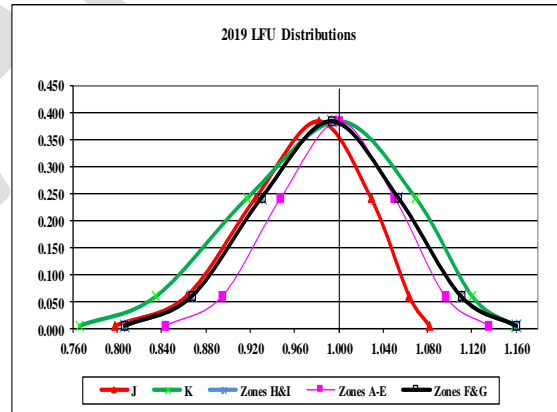
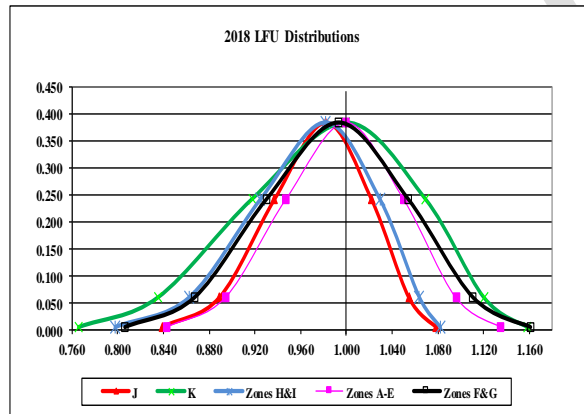

# Attachment B1

## New Non-Wind Units and Unit Re-ratings<sup>3</sup>

B1 - Proposed Non-wind Units and Unit Re-ratings (summer ratings)					
Project or Generator Name	Zone	2018 MARS Model (MW)	2018 Gold Book (MW)	New or Incremental (MW)	2019 MARS Model (MW)
<b>New Units</b>					
Arthur Kill Cogen	J	0	11.1	11.1	11.1
<b>Total New Units</b>		0		11.1	11.1
<b>Existing Unit Re-ratings</b>					
Bethlehem Energy Center	F	808.9	787.2	26.1	813.3
Bayonne Energy Center II	J	482.5	458.2	120.4	578.6
East River 1	J	152.3	153.1	2.8	155.1
East River 2	J	149.1	154.0	6.9	156.0
East River 6	J	136.3	136.3	8.0	144.3
Nine Mile Point 2	C	1246.6	1,246.6	45.1	1291.7
<b>Total Unit Rerates</b>				209.3	
<b>Total New Units + Re-rates</b>				220.4	

<sup>3</sup> Unit re-ratings are for generation facilities that have undergone uprate projects.

# Attachment B2

## Retiring and Ineligible Generating Units

<b>Attachment B2 -Announced Unit Retirements, Deactivations, and ICAP Ineligible Forced Outage (IIFO)</b>			
<b>Generator Name</b>	<b>Zone</b>	<b>CRIS (MW)</b>	<b>CRIS adusted value from 2018 Gold Book (MW)</b>
<b><i>Retirements</i></b>		<b>0.0</b>	<b>0.0</b>
Binghamton BOP	C	43.8	43.7
Selkirk 1	F	82.1	78.2
Selkirk 2	F	291.3	277.3
<b><i>Deactivations</i></b>		<b>417.2</b>	<b>399.2</b>
Ravenswood 9	J	21.7	16.3
Lyonsdale	E	20.2	20.1
Ravenswood 2-1	J	40.4	31.4
Ravenswood 2-2	J	37.6	29.9
Ravenswood 2-3	J	39.2	28.9
Ravenswood 2-4	J	39.8	30.7
Ravenswood 3-1	J	40.5	31.9
Ravenswood 3-2	J	38.1	29.4
Ravenswood 3-4	J	35.8	31.2
<u>Cayuga Unit 2</u>	<u>J</u>	<u>154.7</u>	<u>139.6</u>
<b><i>ICAP Ineligible</i></b>		<b>468.0</b>	<b>389.4</b>
<b>Total Removals</b>		<b>885.2</b>	<b>788.6</b>

# Attachment B3

## New Wind and Bulk Solar<sup>4</sup> Resources

B3 - New Wind and Solar Resources				
Wind Resource	Zone	CRIS (MW)	Summer Capability (MW)	CRIS adusted value from 2018 Gold Book (MW)
<b>New Wind Units</b>				
Copenhagen Wind	E	79.9	79.9	79.9
Arkwright Summit	A	78.4	78.4	78.4
<b>Total New Wind</b>				<b>158.3</b>
<b>New (bulk power) Solar Units</b>				
<b>Total New Solar</b>				<b>0.0</b>
<b>Total New Wind and Solar</b>				
				<b>158.3</b>

<sup>4</sup> Bulk Power System connected solar resources. Distributed solar resource impacts are accounted for in the load forecast.

# Attachment B4

## New Resources in the Behind the Meter Net Generation Program (BTM-NG)

Attachment B4 -Units in the Behind the Meter Net Generation Program*			
Generator Name	Zone	Resource Value (MW) <sup>1</sup>	Peak Load Adjustment (MW) <sup>2</sup>
<b>Existing:</b>			
Stonybrook	K	45.7	40.6
<b>New:</b>			
Greenidge 4	C	104.3	11.6
<b>Total New BTM Gen</b>		150.0	52.2

\* The IRM study independently models the generation and load components of BTM:NG Resources

1. Based on adjusted DMGC value
2. Based on ACHL

# Attachment C

## NYCA Annual EFORDs

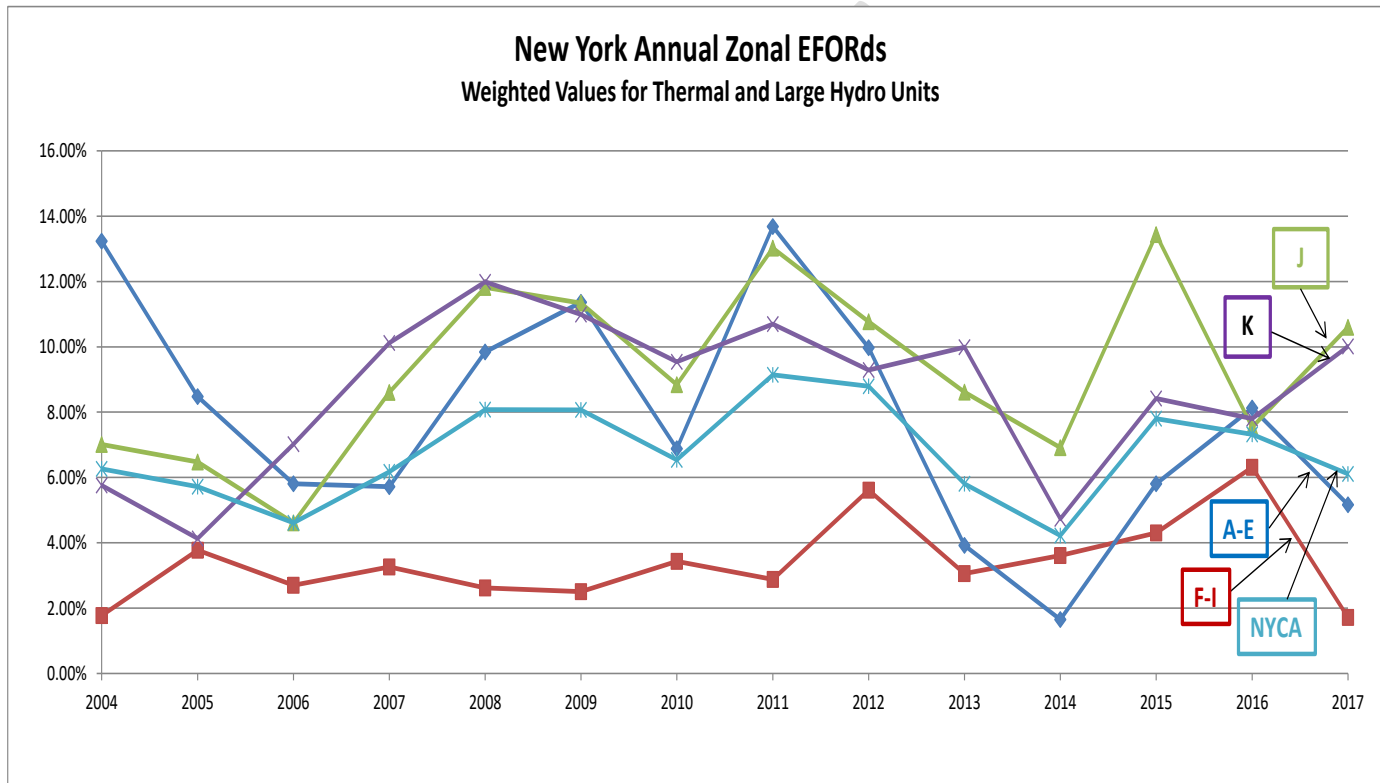



# Attachment C1

## NYCA Five Year EFORDs

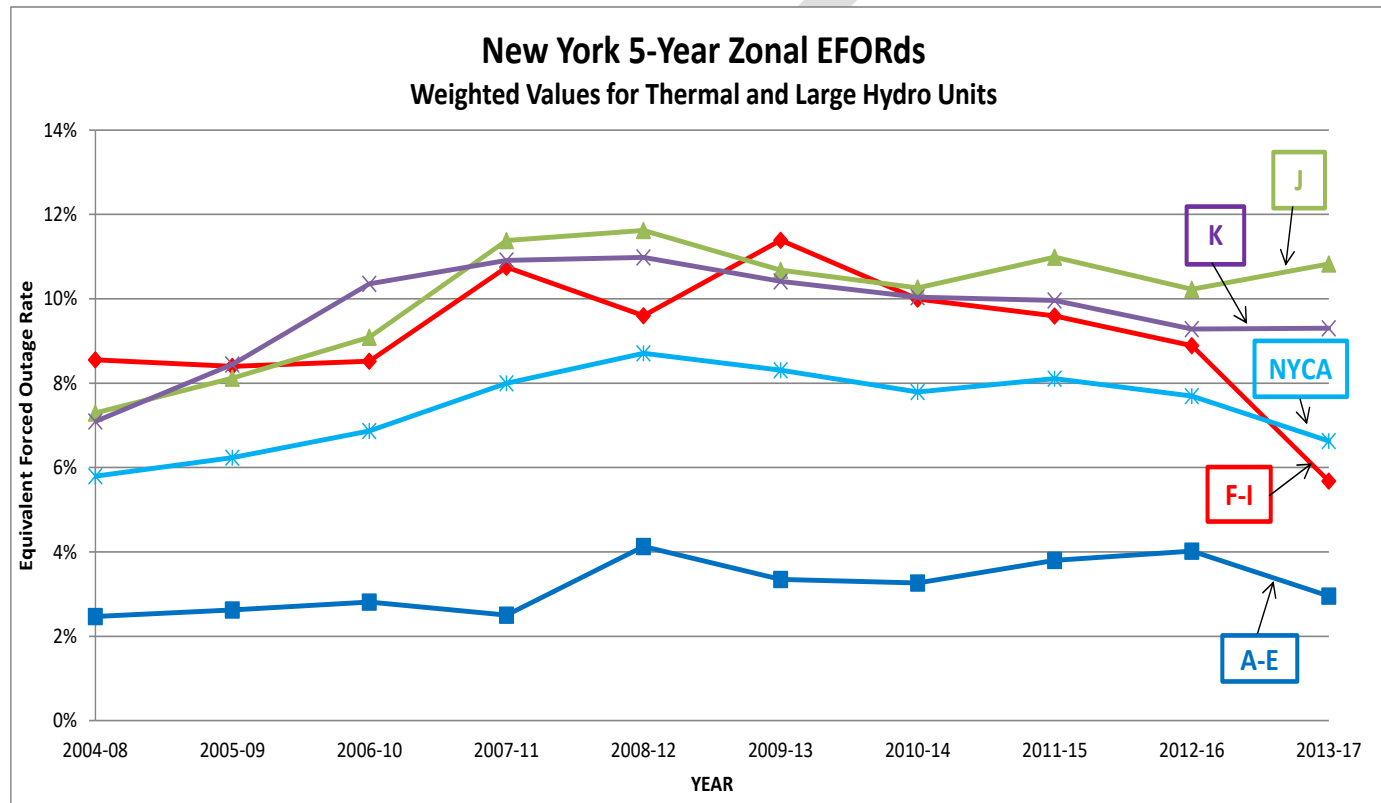

## Attachment D

### Emergency Operating Procedures

<b>Step</b>	<b>Procedure</b>	<b>Effect</b>	<b>2018 MW Value</b>	<b>2019 MW Value</b>
1	Special Case Resources	Load relief	1,219 MW Enrolled/ 868 MW modeled	1309 MW Enrolled/ 903 MW modeled
2	Emergency Demand Response Program	Load relief	16 MW Enrolled/3 MW Modeled	5.5 MW Enrolled/1 MW Modeled
3	5% manual voltage Reduction	Load relief	66 MW	66 MW
4	Thirty-minute reserve to zero	Allow operating reserve to decrease to largest unit capacity (10-minute reserve)	655 MW	655 MW
5	5% remote voltage reduction	Load relief	341 MW	401 MW
6	Voluntary industrial curtailment	Load relief	121.8 MW	165.6 MW
7	General public appeals	Load relief	80.8 MW	80.8 MW
8	Emergency Purchases	Increase capacity	Varies	Varies
9	Ten-minute reserve to zero	Allow 10-minute reserve to decrease to zero	1,310 MW	1,310 MW
10	Customer disconnections	Load relief	As needed	As needed

# Attachment E

## IRM Topology

### 2019 IRM Topology (Summer Limits)

October 3, 2018

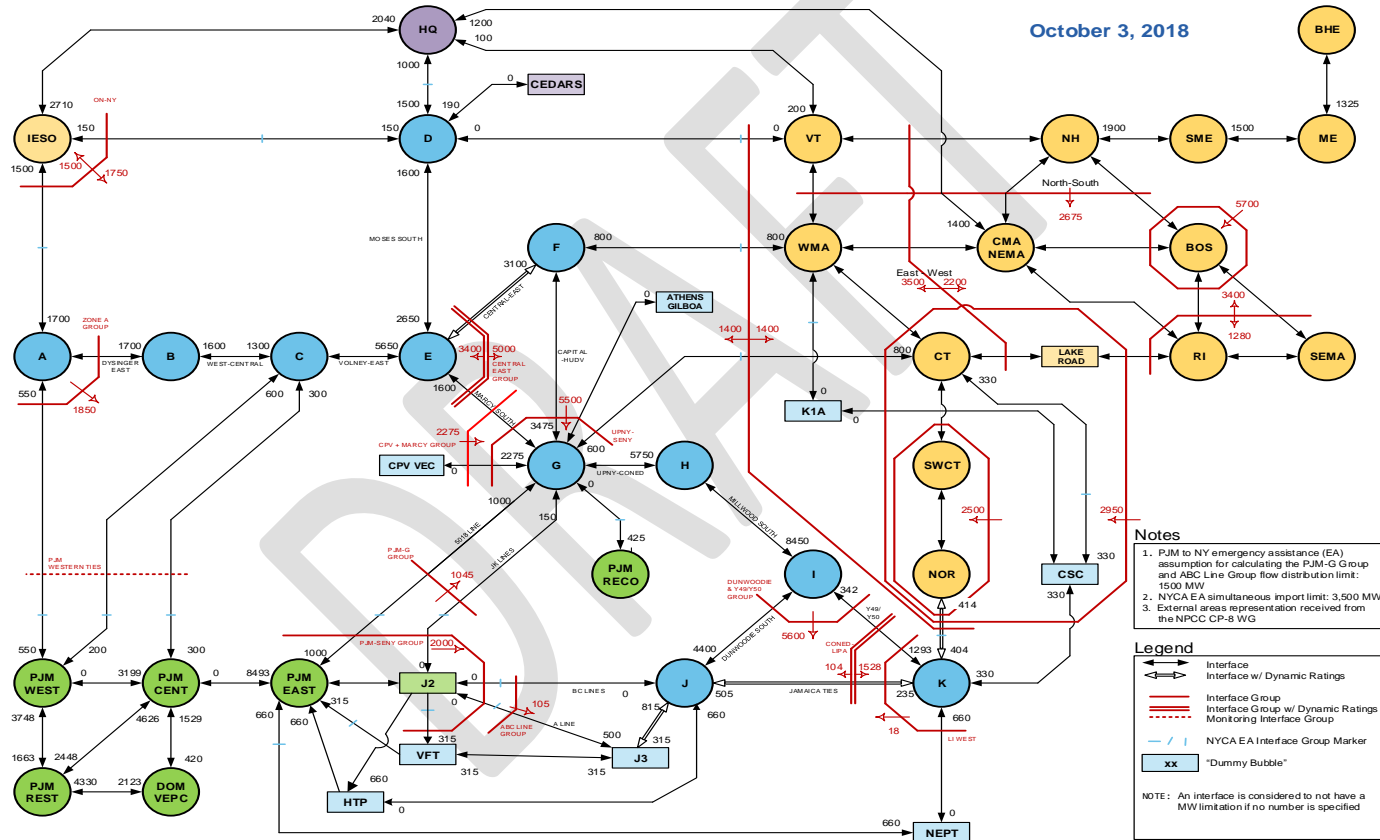

## Attachment F

### SCR/EDRP Determinations

SCR Performance for 2019 IRM Study						
Super Zones	Registrations (July 2018)	Forecast (2019) <sup>1</sup>	Performance Factor <sup>2</sup>	UCAP (2019)	Adjustment Factor <sup>3</sup>	Model Value
A - F	655.1	655.1	0.865	566.6	0.932	528.2
G - I	111.4	111.4	0.748	83.3	0.854	71.1
J	494.1	494.1	0.713	352.1	0.780	274.5
K	48.5	48.5	0.709	34.4	0.842	28.9
<b>Totals</b>	<b>1309.1</b>	<b>1309.1</b>		<b>1036.4</b>		<b>902.7</b>
Notes				Overall Performance:	69.0%	
1. These values represent no growth from the July 2018 ICAP registrations						
2. Performance Factor based on ACL methodology						
3. The Adjustment Factor captures two different performance derates; 1) Translation Factor (TF) between ACL and CBL values, and 2) the Fatigue Factor (FF), (FF = 1.00)						

### EDRP Performance

	A	B	C	D	E	F
		=A*(100%)		=B*C		=D*E
<b>Super Zones</b>	<b>July 2018 Sum of DV</b>	<b>2019 Forecast<sup>1</sup></b>	<b>Performance Factor<sup>2</sup></b>	<b>2018 Sum of DV * PF</b>	<b>Adjustment Factor<sup>3</sup></b>	<b>In Model Value</b>
A-F	4.7	4.7	0.160	0.7	N/A	0.7
G-I	0.2	0.2	0.309	0.1	N/A	0.1
J	0.6	0.6	0.250	0.1	N/A	0.1
K	0.0	0.0	0.142	0.0	N/A	0.0
<b>Total</b>	<b>5.5</b>	<b>5.5</b>		<b>1.0</b>		<b>1.0</b>

1. These values represent a decline from July 2018 EDRP based enrollments.
2. Performance Factor based on CBL response vs Declared Value methodology
3. The Adjustment Factor does not apply to EDRP resources

## Assumption Matrix History

Date	Ver	Preliminary Base Case	Date	Ver	Final Base Case
1/30/18	V0.0	Preliminary assumptions without attachments.			
5/2/18	V1.0	-Attach. A- LFU, no change. -Attachment C & C1 - Gen perform updated. -Attach. E- Topology, no NY change. -New row entry for Land Fill Gas Attachments B1-B4 added	<a href="#"><u>9/26/18</u></a>	<a href="#"><u>V4.0</u></a>	- updated SCR EOP performance -added <del>g</del> Greenidge 4 as <del>btm-ng</del> BTM-NG resource -updated topology to remove B & C lines, reflect lower transfer limits without Par 33 to Ontario
6/22/18	V2.1	Attachments B1-B3 updated, added TPAS change to VFT return path on attachment E	<a href="#"><u>9/27/18</u></a>	<a href="#"><u>V4.1</u></a>	-updated attachment F to include new SCR performance.
6/27/18	V3.0	ICS changes plus Attachments B1, B2, D, and E updated			
7/11/18	V3.1	Add Attachment F for SCRs			
7/13/18	V3.2	Add to Attachment F for EDRP			