

NYCA IRM Requirement Study 2022-2023 Preliminary Base Case (PBC) Model Assumptions Matrix

Draft V 7.0

NYSRC

Installed Capacity Subcommittee Meeting #249

August 4, 2021

Load Forecast Uncertainty

#	Parameter	2021 Model Assumptions	2022 Model Assumptions	Basis for Recommendation	Model Change	Expected Date	Est. IRM Impact*
1	Peak Load Forecast (Preliminary Base Case – Parametric & Sensitivities)	2020 Gold Book NYCA: 32,129MW ¹ NYC: 11,460 MW LI: 5,139 MW G-J: 15,660 MW (Attachment A1)	2021 Gold Book** NYCA: 32,178MW ¹ NYC: 11,268 MW LI: 5,153 MW G-J: 15,435 MW (Attachment A1)	Most recent Gold Book Forecast is used for Preliminary Base Case parametric study and sensitivity cases	N	Data Received	Medium(-)
2	Peak Load Forecast (Final Base Case)	October 2020 Fcst. NYCA: 32,243 MW ² NYC: 11,232 MW LI: 5,282.0 MW G-J: 15,385 MW	October 2021 Fcst. NYCA: xxxxx MW ² NYC: yyyyy MW LI: zzzzz MW G-J: wwww MW	Forecast based on examination of 2021 weather normalized peaks	N	October 2021	TBD
3	Load Shape (Multiple Load Shape)	Bin 1: 2006 Bin 2: 2002 Bins 3-7: 2007	Bin 1: 2006 Bin 2: 2002 Bins 3-7: 2007	ICS Recommendation	N	Data Received	None
4	Load Forecast Uncertainty (LFU)-	Zonal Model to reflect current data with input from Con Ed and LIPA. (Attachment A2)	Zonal Model to reflect current data with input from Con Ed and LIPA. (Attachment A2)	Based on TO and NYISO data analyses	N	Data Received	High (-)
5	LFU Winter	Attachment A3	Attachment A3	Based on TO and NYISO data analyses	N	Data Received	None

*(-) indicates a reduction in IRM while (+) indicates an increase. Range: Low < 0.5%, Medium 0.5% - 1%, High > 1%, Minimal indicates there may be some movement but within 0 to +/- 0.1%.

New Capacity resources will continue to be tracked by the NYISO. The Final Base Case resource list is subject to change based on project status' by October 2021.

1 The loads associated with the BTM-NG program need to be added to these values.

2 BTM-NG loads have been incorporated into these numbers.

Draft

Generation Parameters

#	Parameter	2021 Model Assumptions	2022 Model Assumptions	Basis for Recommendation	Model Change	Expected Date	Est. IRM Impact*
6	Existing Generating Unit Capacities	2020 Gold Book Values. Use min. (DMNC vs. CRIS) capacity value	2021 Gold Book Values. Use min. (DMNC vs. CRIS) capacity value	Latest Gold Book publication	N	Data Received	Low(-)
7	Proposed New Units (Thermal) and re-ratings	0 MW of new Thermal resources, plus 56.6 MW of project related re-ratings. (Attachment B1)	23.7 MW of new Thermal resources,** (Attachment B1)	NYISO recommendation based on documented process that includes the latest Gold Book publication, NYISO interconnection queue, and generation notifications	N	Data Received	Minimal
8	Deactivations and Removals ³	1,104 MW of unit deactivations and 192.7 MW of unit removals (Attachment B2)	19.1 MW of unit deactivations and (Attachment B2)	Latest Gold Book publications and generator notifications	N	Data Received	Minimal
9	Forced and Partial Outage Rates	Five-year (2015-2019) GADS data for each unit represented. Those units with less than five years – use representative data. (Attachment C)	Five-year (2016-2020) GADS data for each unit represented. Those units with less than five years – use representative data. (Attachment C)	Transition Rates representing the Equivalent Forced Outage Rates (EFORd) during demand periods over the most recent five-year period	N	Data Received	Low(-)
10	Planned Outages	Based on schedules received by the NYISO and adjusted for history	Based on schedules received by the NYISO and adjusted for history	Updated schedules	N	Data Received	Low(+)

³Units that did not participate in the Capacity Market have been removed from this year's study

Generation Parameters

#	Parameter	2021 Model Assumptions	2022 Model Assumptions	Basis for Recommendation	Model Change	Expected Date	Est. IRM Impact*
11	Summer Maintenance	Nominal 50 MWs – divided equally between Zones J and K	Nominal 50 MWs – divided equally between Zones J and K	Review of recent data	N	Data Received	Low(+)
12	Combustion Turbine Derates	Derate based on temperature correction curves provided	Derate based on temperature correction curves provided	Operational history indicates the derates are in line with manufacturer’s provided curves	N	Data Received	None
13	Existing and Proposed New Wind Units ⁴	126.5 MW of Wind Capacity additions totaling 1865.7 MW of qualifying wind (Attachment B3)	158.1 MW of Wind Capacity additions totaling 2017.5 MW of qualifying wind (Attachment B3)	ICAP units based on RPS agreements, interconnection queue and ICS input.	N	Data Received	Low(+)
14	Wind Shape	Actual hourly plant output over the period 2015-2019. New units will use zonal hourly averages or nearby units.	Actual hourly plant output over the period 2016-2020. New units will use zonal hourly averages or nearby units.	Program randomly selects a wind shape of hourly production from the most recent five- year period for each model iteration.	N	Data Received	Minimal
15	Existing and Proposed New Solar Resources ⁴	0 MW of Solar Capacity additions totaling 31.5MW of qualifying Solar Capacity. (Attachment B3)	22.9 MW of Solar Capacity additions totaling 54.4 MW of qualifying Solar Capacity. (Attachment B3)	ICAP Resources connected to Bulk Electric System	N	Data Received	Minimal
16	Solar Shape	Actual hourly plant output over the period 2015-2019. New units will use zonal hourly averages or nearby units.	Actual hourly plant output over the period 2016-2020. New units will use zonal hourly averages or nearby units.	Program randomly selects a solar shape of hourly production from the most recent five-year period for each model iteration.	N	Data Received	None

⁴Units that did not participate in the Capacity Market have been removed from this year’s study

Generation Parameters

#inimal	Parameter	2021 Model Assumptions	2022 Model Assumptions	Basis for Recommendation	Model Change	Expected Date	Est. IRM Impact*
17	BTM- NG Program	Two new BTM NG resource (Attachment B5)	One new BTM NG resource (Attachment B5)	Both the generation of the participating resources and the full host loads are modeled.	N	Data Received	Minimal
18	Small Hydro Resources	Actual hourly plant output over the period 2015-2019.	Actual hourly plant output over the period 2016-2020.	Program randomly selects a hydro shape of hourly production from the most recent five-year period for each model iteration.	N	Data Received	Minimal
19	Large Hydro	Probabilistic Model based on five years of GADS data (2015-2019)	Probabilistic Model based on five years of GADS data (2016-2020)	Transition Rates representing the Equivalent Forced Outage Rates (EFORd) during demand periods over the most recent five-year period.	N	Data Received	Minimal
20	Landfill Gas	Actual hourly plant output over the period 2015-2019.	Actual hourly plant output over the period 2016-2020.	Program randomly selects a LFG shape of hourly production from the most recent five-year period for each model iteration.	N	Data Received	Minimal
21	New ESR (Energy Storage Resources) ⁴	0 MW of new battery storage scheduled. 0MW of total battery storage modeled (see attachment B4)	0 MW of new battery storage scheduled. 0 MW of total battery storage modeled (see attachment B4)	Sensitivities on simplified model and GE software enhancement	N	Data Received	None
22	Energy Limited Resources (ELR)	Based upon elections made by August 1 st 2020	Based upon elections made by August 1 st 2021	Existing elections are made by August 1st and will be incorporated into the model.	N	August 2021	Minimal

Draft

Transactions- Imports and Exports

#	Parameter	2021 Model Assumptions	2022 Model Assumptions	Basis for Recommendation	Model Change	Expected Date	Est. IRM Impact*
23	Capacity Purchases	Existing Rights: PJM - 1,080 MW HQ - 1,110 MW All contracts modeled as equivalent contracts	Existing Rights: PJM - 1,080 MW HQ - 1,190 MW All contracts modeled as equivalent contracts. New 80 MW addition	Grandfathered Rights, ETCNL, and other awarded long-term rights.	N	Data Received	None
24	Capacity Sales	Long Term firm sales Summer 265.9 MW	Long Term firm sales Summer 265.9 MW	These are long term FERC approved contracts.	N	Data Received	None
25	FCM Sales from a Locality ⁵	No sales modeled within study period	No sales modeled within study period	NYISO recommendation	N	Data Received	None
26	Wheels through NYCA	300 MW HQ to NE equivalent contract	300 MW HQ to NE equivalent contract	HQ Wheel has an ISO-NE capacity supply obligation (CSO) for 2022-23	N	Data Received	None
27	New UDRs (Unforced capacity Deliverability Rights)	Projects with expired CRIS will be modeled as Emergency Assistance Only: HTP	Projects with expired CRIS will be modeled as Emergency Assistance Only: HTP	Existing UDR elections are made by August 1st and will be incorporated into the model	TBD	August 2021	TBD
28	New EDRs (External Deliverability Rights)	0 MWs for 2021 Study	80 MWs for 2021 Study	80 MWs from Cedars upgrade	Y	Data Received	Minimal

⁵ Final FCM sales that will materialize are unknowable at the time of the IRM study. To reflect the impact these sales have on reliability, the NYISO applies a Locality Exchange Factor in the market.

Topology

#	Parameter	2021 Model Assumptions	2022 Model Assumptions	Basis for Recommendation	Model Change	Expected Date	Est. IRM Impact*
29	Interface Limits	Removal of PJM-SENY Group Interface, PSEG-LI updates to increase Zone K Imports/Exports: Jamaica ties no longer dependent on Barrett Availability (Attachment E-E2)	Revisions due to Western NY Public Policy impacts, Central East derate, Cedars upgrade (Attachment E-E2)	Based on the most recent NYISO studies and processes, such as Operating Study, Operations Engineering Voltage Studies, Comprehensive System Planning Process, and additional analysis including interregional planning initiatives.	Y	Data Received	None
30	New Transmission	None Identified	Cedars EDR from HQ	Based on TO provided models and NYISO's review	Y	Data Received	Minimal
31	AC Cable Forced Outage Rates	All existing Cable EFORDs for NYC and LI to reflect most recent five-year history (2015-2019)	All existing Cable EFORDs for NYC and LI to reflect most recent five-year history (2016-2020) (Attachment E3)	TO provided transition rates with NYISO review.	N	Data Received	Minimal
32	UDR Line Unavailability	Five year history of forced outages (2015-2019)	Five year history of forced outages (2016-2020)	NYISO/TO Review	N	Data Received	Minimal

Emergency Operating Procedures

#	Parameter	2021 Model Assumptions	2022 Model Assumptions	Basis for Recommendation	Model Change	Expected Date	Est. IRM Impact*
33	Special Case Resources	July 2020 –1195 MW based on registrations and modeled as 822 MW of effective capacity. Monthly variation based on historical experience.	July 2021 –1164 MW based on registrations and modeled as 812 MW of effective capacity. Monthly variation based on historical experience.	SCRs sold for the program discounted to historic availability. Summer values calculated from July 2021 registrations. Performance calculation updated per ICS presentations on SCR performance.	N	<i>Data Received</i>	Minimal
34	Other EOPs	844.4 MW of non- SCR/non-EDRP resources (Attachment D)	863.6 MW of non- SCR/non-EDRP resources (Attachment D)	Based on TO information, measured data, and NYISO forecasts	N	<i>Data Received</i>	Low(-)
35	EOP Structure	10 EOP steps modeled	10 EOP steps modeled	Based on agreement with ICS	N	<i>Data Received</i>	None

External Control Areas

#	Parameter	2021 Model Assumptions	2022 Model Assumptions	Basis for Recommendation	Model Change	Expected Date	Est. IRM Impact*
36	PJM	Load and Capacity data will be provided by ISONE/NPCC CP-8 Data may be adjusted per NYSRC Policy 5 (Attachment E & E3)	Load and Capacity data will be provided by ISONE/NPCC CP-8 Data may be adjusted per NYSRC Policy 5 (Attachment E)	Initial Review performed by the NPCC CP-8 WG prior to Policy 5 changes	N	Data Received	Medium(-)
37	ISONE, Quebec, IESO	Load and Capacity data will be provided by ISONE/NPCC CP-8 Data adjusted per NYSRC Policy 5 (Attachment E & E2)	Load and Capacity data will be provided by ISONE/NPCC CP-8 Data adjusted per NYSRC Policy 5 (Attachment E)	Initial Review performed by the NPCC CP-8 WG prior to Policy 5 changes	N	Data Received	Low(+)
38	External Adjustments per Policy 5	If needed, add load to externals proportional to existing excess capacity	If needed, add load to externals proportional to existing excess capacity	White paper on external Control Area adjustments	N	Data Received	Low(+)
39	Reserve Sharing	All NPCC Control Areas indicate that they will initially share reserves equally among all members and then among non-members	All NPCC Control Areas indicate that they will initially share reserves equally among all members and then among non-members	Per NPCC CP-8 WG	N	Data Received	None
40	Emergency Assistance	Statewide Limit of 3,500 MW of emergency assistance allowed from neighbors.	Statewide Limit of 3,500 MW of emergency assistance allowed from neighbors.	White Paper on Modeling of Emergency Assistance for NYCA in IRM studies	N	Data Received	None

Miscellaneous

#	Parameter	2021 Model Assumptions	2022 Model Assumptions	Basis for Recommendation	Model Change	Expected Date	Est. IRM Impact*
41	MARS Model Version	3.31.1546	4.2.1765	Per testing and ICS recommendation	Y	Received	None
42	Environmental Initiatives	No new rules for 2021 Capability Year	No new rules for 2022 Capability Year	Review of existing regulations and rules	N	July 2021	

Draft

Attachment A1

NYCA Summer Load Forecast Coincident and Non-Coincident Peak:
2021 and 2022

2022 PBC													
Area	A	B	C	D	E	F	G	H	I	J	K	NYCA	G_J
NCP - Forecast	2799	2056.4	2847.8	692	1420	2385	2215	648	1400	11286.2	5191.6		
CP - Forecast	2644	1994.4	2781.8	676	1361	2347	2179	637	1379	11134.2	5174.6	32308	
G-J Peak - Forecast							2197	642	1390	11224.2			15453.2

2021 FBC													
Area	A	B	C	D	E	F	G	H	I	J	K	NYCA	G_J
NCP - Forecast	2806.3	2033.8	2972.4	653.4	1465.7	2442.8	2231.9	642.6	1394.1	11232.3	5282		
CP - Forecast	2626.8	1955.2	2850.2	617.6	1398.6	2365.9	2193.6	631.1	1369	11031	5204	32243	
G-J Peak - Forecast							2216.9	637.8	1383.5	11147.1			15385.3

Delta													
Area	A	B	C	D	E	F	G	H	I	J	K	NYCA	G_J
NCP - Forecast	-7.3	22.6	-124.6	38.6	-45.7	-57.8	-16.9	5.4	5.9	53.9	-90.4		
CP - Forecast	17.2	39.2	-68.4	58.4	-37.6	-18.9	-14.6	5.9	10	103.2	-29.4	65	
G-J Peak - Forecast							-19.9	4.2	6.5	77.1			67.9

Attachment A2

NYCA Summer Load Forecast Uncertainty Model: 2021 and 2022

Load Forecast 2022

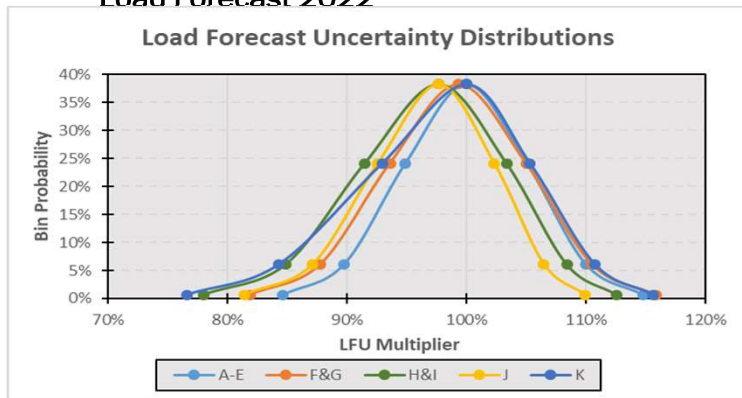

Bin	Probability	A-E	F&G	H&I	J	K
B1	0.62%	114.78%	115.85%	112.55%	109.95%	115.63%
B2	6.06%	110.01%	110.53%	108.40%	106.49%	110.73%
B3	24.17%	105.06%	105.01%	103.36%	102.33%	105.30%
B4	38.30%	100.00%	99.36%	97.68%	97.67%	100.00%
B5	24.17%	94.88%	93.61%	91.50%	92.58%	92.96%
B6	6.06%	89.73%	87.77%	84.89%	87.13%	84.32%
B7	0.62%	84.63%	81.88%	77.98%	81.38%	76.60%
Delta		A-E	F&G	H&I	J	K
B1 - B4	14.78%	16.49%	14.87%	12.28%	15.63%	
B4 - B7	15.37%	17.48%	19.70%	16.29%	23.40%	
Total Range	30.15%	33.97%	34.57%	28.57%	39.03%	

Load Forecast 2021

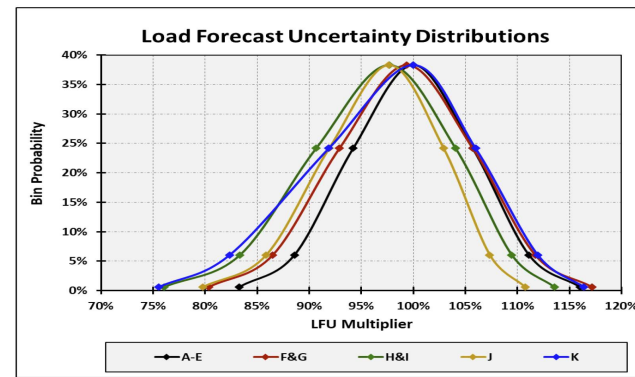

Bin	Probability	A-E	F&G	H&I	J	K
B1	0.62%	116.02%	117.17%	113.56%	110.73%	116.38%
B2	6.06%	111.11%	111.70%	109.46%	107.33%	111.97%
B3	24.17%	105.70%	105.70%	104.06%	102.89%	105.98%
B4	38.30%	100.00%	99.36%	97.68%	97.67%	100.00%
B5	24.17%	94.22%	92.89%	90.66%	91.91%	91.88%
B6	6.06%	88.58%	86.48%	83.35%	85.86%	82.34%
B7	0.62%	83.28%	80.33%	76.06%	79.79%	75.52%
Delta		A-E	F&G	H&I	J	K
B1 - B4	16.02%	17.80%	15.88%	13.06%	16.38%	
B4 - B7	16.72%	19.04%	21.62%	17.88%	24.48%	
Total Range	32.74%	36.84%	37.50%	30.94%	40.87%	

Attachment A3

NYCA Winter Load Forecast Uncertainty Model: 2021 and 2022

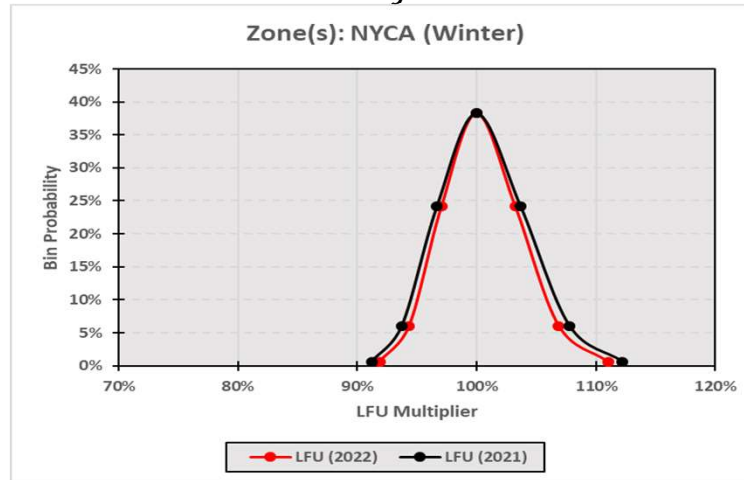

Bin	Probability	LFU (2022)	LFU (2021)
B1	0.62%	111.01%	112.22%
B2	6.06%	106.89%	107.77%
B3	24.17%	103.25%	103.69%
B4	38.30%	100.00%	100.00%
B5	24.17%	97.05%	96.69%
B6	6.06%	94.34%	93.76%
B7	0.62%	91.85%	91.22%

Draft

Attachment B1

New Thermal Units and Unit Re-Ratings⁷

New Thermal Units and Unit Re-ratings (summer ratings)					
Project or Generator Name	Zone	2021 Gold Book (MW) CRIS	2021 Gold Book (MW) DMNC	New or Incremental (MW)	2022 MARS Model (MW)
New Units					
King's Plaza	J	6.0	6.0	6	6
Fulton County Landfill*	F	3.2	3.2	3.2	3.2
Ontario Landfill*	B	11.2	11.2	3.6	11.2
Sithe Independence**	C	1013.0	995.0	10.9	1005.9
Total New Units and Uprates (MW)				23.7	

⁷ Unit re-ratings are for generation facilities that have undergone uprate projects.

*Existing LFG units with incremental DMNC and/or CRIS; modeled in MARS with shapes

**1013 and 995 MW are 2021 Gold Book values prior to generator re-ratings

Attachment B2

Deactivations and Removals⁴

Unit Removal since 2021 IRM Study			
Generator Name	Type	Zone	CRIS (MW)
Gowanus 1-8	Gas Turbine	J	16.1
Sissonville	Hydro	B	3
Total Removals			19.1

⁴Units that did not participate in the Capacity Market have been removed from this year's study

Attachment B3

New Intermittent Resources

Wind				
Resource	Zone	CRIS (MW)	Summer Capability (MW)	MARS Modeled Capacity
New Wind Units				
Arkwright Summit Wind Farm*	A	78.4	78.4	78.4
Roaring Brook	E	79.7	79.7	79.7
Total				158.1

Solar				
Resource	Zone	CRIS (MW)	Summer Capability (MW)	MARS Modeled Capacity
New Solar Units				
Calverton Solar Energy Center	K	22.9	22.9	22.9
Total				22.9

*This is an existing resource that became an ICAP supplier

Draft

Attachment B4

New Energy Storage Resources*

Energy Storage				
Resource	Zone	CRIS (MW)	Summer Capability (MW)	Lesser of Summer Capability VS CRIS
New Battery Units				
Total New Energy Storage				

Draft

Attachment B5

Resources in the Behind the Meter Net Generation Program (BTM-NG)

Attachment B4 -Units in the Behind the Meter Net Generation Program*			
Generator Name	Zone	Resource Value (MW) ⁹	Peak Load Adjustment (MW) ¹⁰
Existing:			
Stony Brook	K	36.2	42.0
Greenidge 4	C	103.4	32.0
Lyons Falls Hydro	E	8.0	2.7
(CONFIDENTIAL)***	J		21.3
New:			
Red Rochester	B	74	51.4
Total BTM-NG			149.4

*The IRM study independently models the generation and load components of BTM:NG Resources

⁹Based on adjusted Dependable Maximum Gross Capability (DMGC) value

¹⁰Based on Average Coincident Host Load (ACHL)

*** One existing resource in Zone J is expected to begin participating in the BTM:NG program prior to 6/1/2022

Draft

Attachment C

NYCA Five Year Derating Factors*

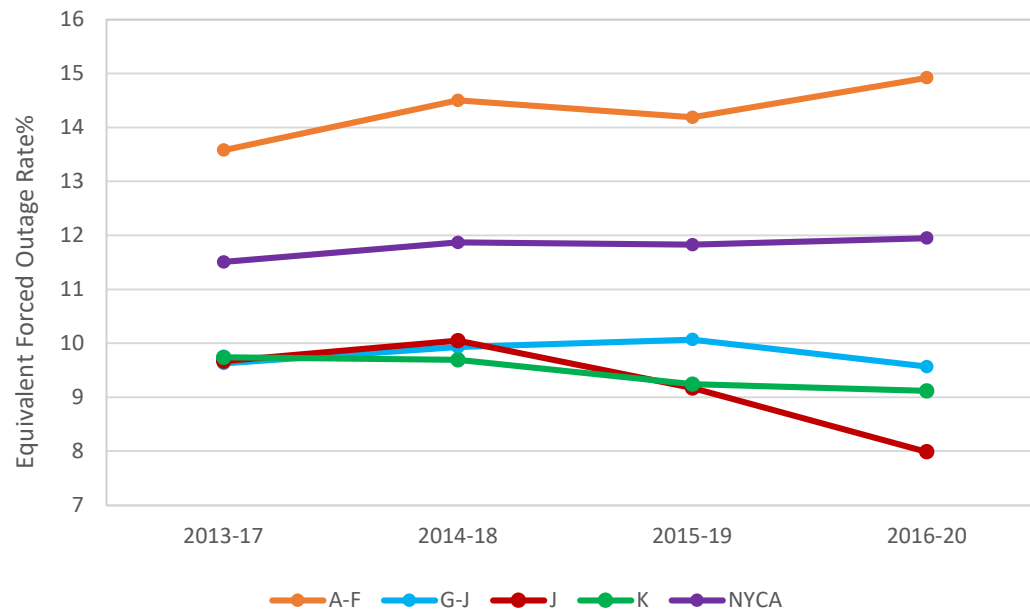

The resources included in the calculation of these values include thermal, large hydro, wind, solar, landfill gas, and run-of-river resources with CRIS

*2016-20 Derating Factor values are preliminary

Attachment D

Emergency Operating Procedures

Step	Procedure	2021 MW Value	2022 MW Value
1	Special Case Resources –Load, Gen	1,195 MW Enrolled/ 822 MW modeled	1,164 MW Enrolled/ 812 MW modeled
2	5% manual voltage Reduction	59.64 MW	60.43 MW
3	Thirty-minute reserve to zero	655 MW	655 MW
4	5% remote voltage reduction	445.42 MW	483.09 MW
5	Voluntary industrial curtailment	259.36 MW	240.05 MW
6	General Public Appeals	80 MW	80 MW
7	Emergency Purchases	Varies	Varies
8	Ten-minute reserves to zero	1,310 MW	1,310 MW
9	Customer disconnections	As needed	As needed
10	Adjustment used if IRM is lower than technical study margin	As needed	As needed

Draft

Attachment E1

IRM Topology

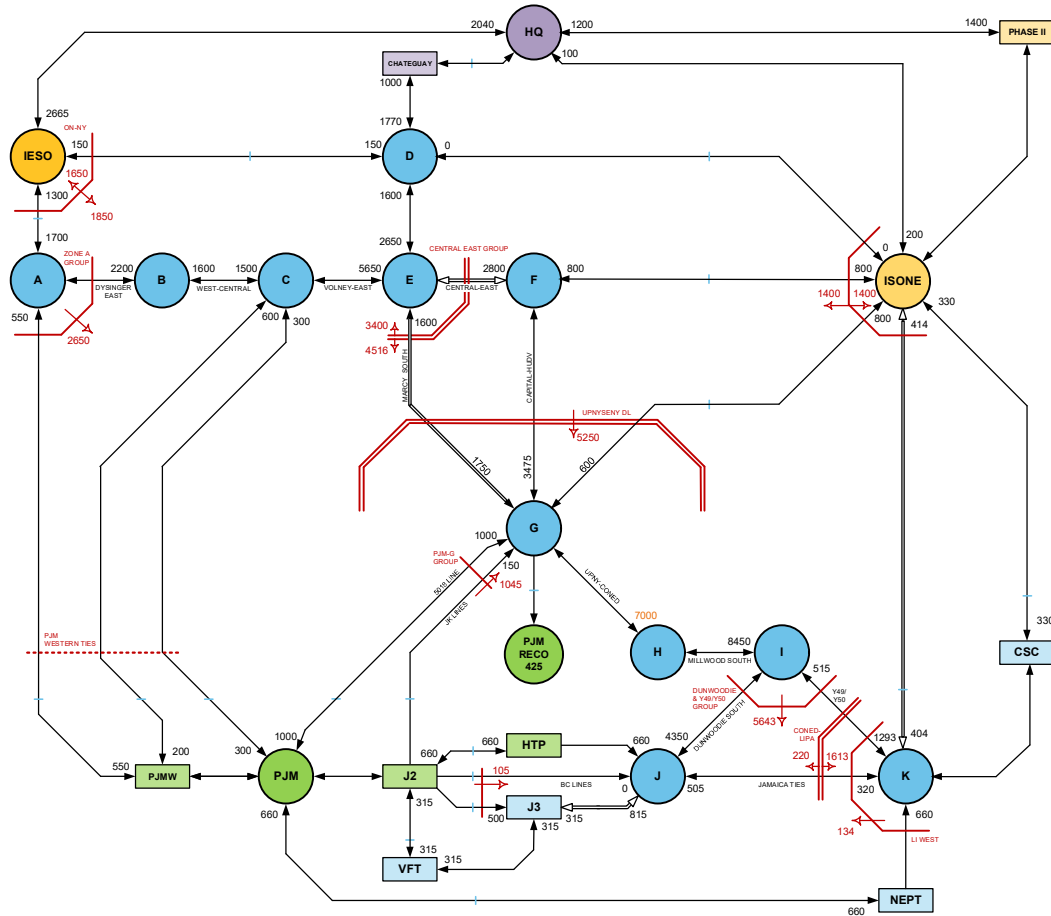

- Notes**
1. PJM to NY emergency assistance (EA) assumption for calculating the PJM-NY Western ties, PJM-G Group, and ABC Line Group flow distribution limit: 1500MW
 2. NYCA EA simultaneous import limit: 3,500 MW
 3. External areas representation based upon information received from the NPCC CP-8 WG

Legend

Draft

Attachment E2

ISO-NE 14 Bubble Model

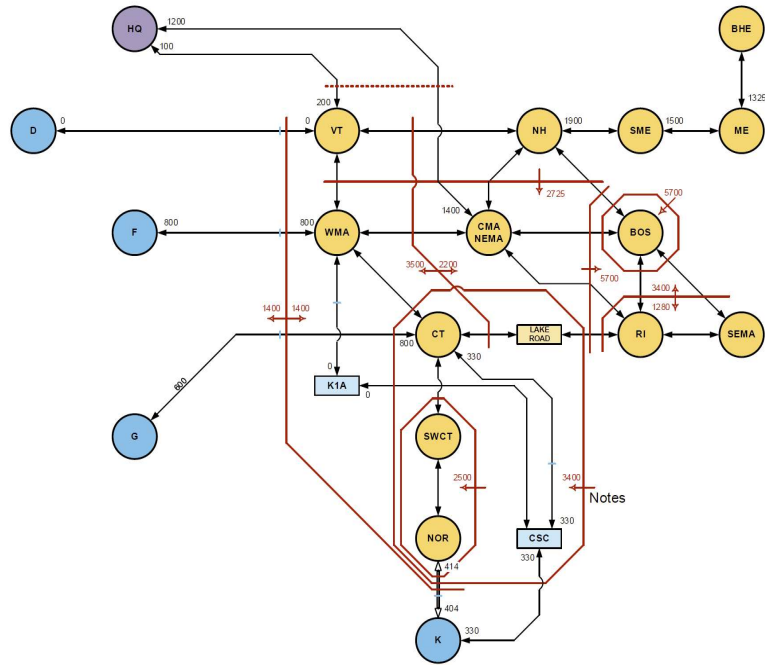

Attachment E3

PJM Bubble Model

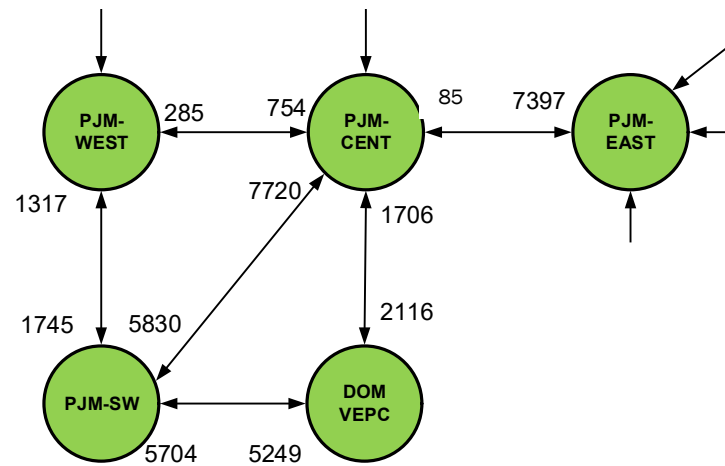

Attachment E4

5 Year Average Cable Outage Rate	
2016-20	2015-19
6.42%	5.15%

The facilities included in these averages are VFT, HTP, Dunwoodie-South, Y49/Y50, CSC, Neptune, Norwalk-Northport and A-Line

Attachment F

SCR Determinations 2022 and 2021 IRM Studies

SCR Performance for 2022 IRM Study						
Super Zones	Enrollments (July 2021)	Forecast (2022) ¹	Performance Factor ²	UCAP (2022)	Adjustment Factor ³	Model Value
A-F	636.0	636.0	0.866	550.9	0.949	812.5
G-I	84.9	84.9	0.772	65.5	0.846	55.5
J	406.5	406.5	0.701	284.9	0.746	212.4
K	36.8	36.8	0.735	27.0	0.822	22.2
Totals	1164.2	1164.2		928.4		812.5
					Overall Performance = 69.8%	

SCR Performance for 2021 IRM Study						
Super Zones	Enrollments (July 2020)	Forecast (2021) ¹	Performance Factor ²	UCAP (2021)	Adjustment Factor ³	Model Value
A-F	622.8	622.8	0.862	537.2	0.949	509.5
G-I	102.0	102.0	0.747	76.2	0.851	64.9
J	427.3	427.3	0.693	296.2	0.752	222.7
K	43.0	43.0	0.706	30.3	0.821	24.9
Totals	1195.1	1195.1		940.0		822.1
					Overall Performance = 68.8%	

1. These values represent no growth from July 2020 ICAP based enrollments.
2. Performance Factor based on ACL methodology
3. The SCR Adjustment factor captures two different performance derates; 1) Calculated Translation Factor (TF) between ACL and CBL values, and the Fatigue Factor (FF=1.00)

Draft

Attachment G

Wind Units Modeled

Resource	Zone	Wind		
		CRIS (MW)	Summer Capability (MW)	MARS Modeled Capability**
Bliss Wind Power [WT]	A	100.5	100.5	100.5
Canandaigua Wind Power [WT]	C	125.0	125.0	125.0
High Sheldon Wind Farm [WT]	C	112.5	118.1	112.5
Howard Wind [WT]	C	57.4	55.4	55.4
Orangeville Wind Farm [WT]	C	94.4	93.9	93.9
Wethersfield Wind Power [WT]	C	126.0	126.0	126.0
Altona Wind Power [WT]	D	97.5	97.5	97.5
Chateaugay Wind Power [WT]	D	106.5	106.5	106.5
Clinton Wind Power [WT]	D	100.5	100.5	100.5
Ellenburg Wind Power [WT]	D	81.0	81.0	81.0
Jericho Rise Wind Farm [WT]	D	77.7	77.7	77.7
Marble River Wind [WT]	D	215.2	215.2	215.2
Hardscrabble Wind [WT]	E	74.0	74.0	74.0
Madison Wind Power [WT]	E	11.5	11.6	11.5
Maple Ridge Wind [WT01]	E	231.0	231.0	231.0
Maple Ridge Wind [WT02]	E	90.7	90.8	90.7
Munnsville Wind Power [WT]	E	34.5	34.5	34.5
Cassadaga Wind [WT]	A	126.0	126.5	126.0
Arkwright Summit Wind Farm [WT]*	A	78.4	78.4	78.4
Roaring Brook [WT]	E	79.7	79.7	79.7
Total		2020.0	2023.8	2017.5

*This is an existing resource that became an ICAP supplier

Draft

Attachment G1

Wind Units Not Currently Participating in ICAP Market

Wind					
Resource	Zone	Nameplate (MW)	CRIS (MW)	Summer Capability (MW)	MARS Modeled Capacity
Erie Wind [WT]	A	15.0	0.0	0.0	0.0
Steel Wind [WT]	A	20.0	0.0	0.0	0.0
Western NY Wind Power [WT]	B	6.6	0.0	0.0	0.0
Marsh Hill Wind Farm [WT]	C	16.2	0.0	0.0	0.0
Copenhagen Wind [WT]	E	79.9	79.9	0.0	0.0
Fenner Wind [WT]	C	30.0	0.0	0.0	0.0
Total		167.7	79.9	0.0	0.0

Draft

Attachment G2

Solar Units Modeled

Solar				
Resource	Zone	CRIS (MW)	Summer Capability (MW)	Lesser of Summer Capability VS CRIS
Long Island Solar Farm [PV]	K	31.5	31.5	31.5
Calverton Solar Energy Center [PV]	K	22.9	22.9	22.9
Total		54.4	54.4	54.4

Draft

Attachment G3

Solar Units Not Modeled

Solar				
Resource	Zone	CRIS (MW)	Summer Capability (MW)	Lesser of Summer Capability VS CRIS
Shoreham Solar [PV]*	K	24.9	0.0	0.0
Total		24.9	0.0	0.0

*Unit provides power at the distribution rather than at the transmission level

Draft

Attachment G4

LFG Units Modeled

LFG				
Resource	Zone	CRIS (MW)	Summer Capability (MW)	Lesser of Summer Capability VS CRIS
CHAFEE [IC]	A	6.4	6.4	6.4
Model City Energy LFGE [IC]	A	5.6	5.6	5.6
Modern LFGE [IC]	A	6.4	6.4	6.4
Hyland LFGE [IC]	B	4.8	4.8	4.8
Mill Seat [IC]	B	6.4	6.4	6.4
Broome 2 [IC]	C	2.0	2.0	2.0
Broome LFGE [IC]	C	2.1	2.1	2.1
High Acres Group [IC] (23767)	C	9.6	9.6	9.6
Ontario LFGE [IC]	C	11.2	11.2	11.2
Seneca Energy Group [IC] (23797)	C	17.6	17.6	17.6
Clinton LFGE [IC]	D	6.4	6.4	6.4
DANC LFGE [IC]	E	6.4	6.4	6.4
Madison County LFGE [IC]	E	1.6	1.6	1.6
Oneida-Herkimer LFGE [IC]	E	3.2	3.2	3.2
Colonie LFGTE [IC]	F	6.4	6.4	6.4
Fulton County Landfill [IC]	F	3.2	3.2	3.2
Totals		99.3	99.3	99.3

Draft

Attachment G5

LFG Units Not Modeled

LFG				
Resource	Zone	CRIS (MW)	Summer Capability (MW)	Lesser of Summer Capability VS CRIS
Albany LFGE	F	4.5	5.6	4.5
Total		4.5	5.6	4.5

Draft

Assumption Matrix History

Date	Ver	Preliminary Base Case	Date	Ver	Final Base Case
1/28/21	V0.0	Preliminary assumptions without attachments.			
2/3/21	V1.0	Preliminary assumptions without attachments.			
3/3/21	V2.0	Preliminary assumptions without attachments.			
3/30/21	V3.0	Preliminary assumptions without attachments.			
5/5/21	V4.0	Added in LFU Models, Data from Draft of Gold Book A-B4 and E			
6/2/21	V5.0	Updated Attachments A-B5, D, E, and G-G5			
6/28/21	V6.0				
8/4/21	V7.0				

Draft