

NYCA IRM Requirement Study 2025-2026 Final Base Case (FBC) Model Assumptions Matrix

Draft V1.0

NYSRC

Installed Capacity Subcommittee Meeting #294

October 2, 2024

Load Forecast

#	Parameter	2024 Model Assumptions	2025 Model Assumptions	Basis for Recommendation	Model Change
1	Peak Load Forecast (Preliminary Base Case – Parametric & Sensitivities)	2023 Gold Book ¹ NYCA: 32,451.5 MW NYC: 11,303 MY LI: 5,090.1 MW G-J: 15,439 MW (Attachment A1)	2024 Gold Book ¹ NYCA: 31,832.2 MW NYC: 11,227.5 MY LI: 5,077.9 MW G-J: 15,298.5 MW (Attachment A1)	Most recent Gold Book Forecast is used for Preliminary Base Case parametric study and sensitivity cases	N
2	Peak Load Forecast (Final Base Case)	October 2023 Fcst NYCA: 31,765.6 MW ¹ NYC: 11,170.6 MW LI: 5,080.3 MW G-J: 15,273.5 MW	<i>(Expected October 2024)</i>	Updated Load Forecast in October will be used for Final Base Case (FBC)	TBD
3	Load Shape (Multiple Load Shape)	Bin 1-2: 2013 Bin 3-4: 2018 Bin 5-7: 2017	Bin 1-2: 2013 Bin 3-4: 2018 Bin 5-7: 2017	ICS Recommendation	N
4	Load Forecast Uncertainty (LFU)	Zonal Model to reflect current data with input from Con Ed and LIPA. (Attachment A2)	Zonal Model to reflect current data with input from Con Ed and LIPA. (Attachment A2)	Based on TO and NYISO data analysis	N
5	LFU Winter	Attachment A3	Attachment A3	Based on TO and NYISO data analysis	N

¹ Behind-the-Meter Net Generation (BTM:NG) resource loads have been incorporated into these numbers.

² The loads associated with the BTM:NG program need to be added to these values.

Generation Parameters

#	Parameter	2024 Model Assumptions	2025 Model Assumptions	Basis for Recommendation	Model Change
6	Existing Generating Unit Capacities	2023 Gold Book Values. Use min. (DMNC vs. CRIS) capacity value	2024 Gold Book Values. Use min. (DMNC vs. CRIS) capacity value	Latest Gold Book publication	N
7	Proposed New Units (Thermal) and re-ratings	0 MW of new Thermal resources (Attachment B1)	47.0 MW summer re-rating for Thermal resources (Attachment B1)	NYISO recommendation based on documented process that includes the latest Gold Book publication, NYISO interconnection queue, and generation notifications	N
8	Deactivations and Removals ³	-140.1 MW unit deactivations (Attachment B2)	165.4 MW unit deactivations (Attachment B2)	Latest Gold Book publications and generator notifications	N
9	Forced and Partial Outage Rates	Five-year (2018-2022) GADS data for each unit represented. Those units with less than five years – use representative data. (Attachment C)	Five-year (2019-2023) GADS data for each unit represented. Those units with less than five years – use representative data. (Attachment C)	Transition Rates representing the Equivalent Forced Outage Rates (EFORd) during demand periods over the most recent five-year period	N
10	Planned Outages	Planned Outages are removed from the IRM study	Planned Outages are removed from the IRM study	Based on 2022-2023 IRM study FBC	N

³ Negative values in the ‘SUMMER CRIS (MW)’ column represent units that were previously expected to deactivate due to the NYSDEC “Peaker Rule” requirements for 2023 but did not deactivate. Therefore, they were reinstated in the 2024-25 IRM Study.

Generation Parameters

#	Parameter	2024 Model Assumptions	2025 Model Assumptions	Basis for Recommendation	Model Change
11	Summer Maintenance	Nominal 50 MW – divided equally between Zones J and K	Nominal 50 MW – divided equally as 2 negative 25MW units in Load Zones J and K	Review of most recent data Per NYSRC recommendation	N
12	Combustion Turbine Derates	Derate based on temperature correction curves provided	Derate based on temperature correction curves provided	Operational history indicates the derates are in line with manufacturer’s provided curves	N
13	Existing and Proposed New Wind Units	136 MW of offshore wind capacity additions totaling 2,502.3 MW of qualifying wind. (Attachment B3)	0 MW of offshore wind capacity additions 2,566.20 MW of qualifying wind. (Attachment B3)	ICAP based on clean energy standard (CES) agreements, interconnection queue and ICS input.	N
14a	Land-Based Wind Shape	Actual hourly plant output over the period 2018-2022. New units will use zonal hourly averages or nearby units.	Actual hourly plant output over the period 2019-2023. New units will use zonal hourly averages or nearby units.	Program randomly selects a wind shape of hourly production from the most recent five-year period for each model iteration.	N
14b	Offshore Wind Shape	Normalized offshore wind shapes as published by NYISO over the period 2017-2021	Normalized offshore wind shapes as published by NYISO over the period 2017-2021	Program randomly selects a wind shape of hourly production from the most recent five-year period for each model iteration.	N
15	Existing and Proposed New Solar Resources	90 MW of utility-scale solar capacity additions totaling 304.4 MW of qualifying solar capacity. (Attachment B3)	267 MW of utility-scale solar capacity additions totaling 571.4 MW of qualifying solar capacity. (Attachment B3)	ICAP based on CES agreements, interconnection queue and ICS input.	N
16	Solar Shape	Actual hourly plant output over the period 2018-2022. New units will use zonal hourly averages or nearby units.	Actual hourly plant output over the period 2019-2023. New units will use zonal hourly averages or nearby units.	Program randomly selects a solar shape of hourly production from the most recent five-year period for each model iteration.	N

Generation Parameters

#	Parameter	2024 Model Assumptions	2025 Model Assumptions	Basis for Recommendation	Model Change
17	BTM:NG Program	One new BTM:NG resource: Oxbow (Zone A) – 3.2 MW, with the total of 148.8 MW (Attachment B5)	No new BTM:NG resources, total of 182.2 MW (Attachment B5)	Both the generation of the participating resources and the full host loads are modeled	N
18	Small Hydro Resources	Actual hourly plant output over the period 2018-2022	Actual hourly plant output over the period 2019-2023	Program randomly selects a hydro shape of hourly production from the most recent five-year period for each model iteration.	N
19	Large Hydro	Probabilistic model based on five years of GADS data (2018-2022)	Probabilistic model based on five years of GADS data (2019-2023)	Transition Rates representing the EFORD during demand periods over the most recent five-year period.	N
20	Landfill Gas (LFG)	Actual hourly plant output over the period 2018-2022.	Actual hourly plant output over the period 2019-2023.	Program randomly selects an LFG shape of hourly production from the most recent five-year period for each model iteration.	N
21	New Energy Storage Resources (ESRs)	0 MW of new battery storage scheduled. 20 MW of total battery storage modeled.	0 MW of new battery storage scheduled. 20 MW of total battery storage modeled.	ICAP based on NYSERDA/utility agreements, interconnection queue and ICS input.	N
22	Energy Limited Resources (ELRs)	Based upon elections made by August 1 st , 2023 ES and small EL3 output limitations lifted at HB14	Based upon elections made by August 1 st , 2024 ES and small EL3 output limitations lifted at HB14	Existing elections are made by August 1 st and will be incorporated into the model	N

Transactions- Imports and Exports

#	Parameter	2024 Model Assumptions	2025 Model Assumptions	Basis for Recommendation	Model Change
23	Capacity Purchases	Existing Rights: PJM – 1,013 MW HQ – 1,190 MW All contracts modeled as equivalent contracts.	Existing Rights: PJM – 1,013 MW HQ – 1,190 MW All contracts modeled as equivalent contracts.	Grandfathered Rights, Existing Transmission Capacity for Native Load (ETCNL), and other awarded long-term rights	N
24	Capacity Sales	Long Term firm sales Summer 265.3 MW	Long Term firm sales Summer 266.6 MW	Long term contracts	N
25	Forward Capacity Market (FCM) Sales from a Locality ⁴	No sales modeled within study period	No sales modeled within study period	White paper, NYISO recommendation	N
26	Wheels through NYCA	300 MW HQ to NE equivalent contract	300 MW HQ to NE equivalent contract	HQ wheel has an ISO-NE capacity supply obligation for 2025-2026	N
27	New Unforced Capacity Deliverability Rights (UDRs)	No new UDRs Identified	No new UDRs Identified	Existing UDR elections are made by August 1 st and will be incorporated into the model for FBC	N
28	New External Deliverability Rights (EDRs)	No new EDRs Identified	No new EDRs Identified	Existing EDRs are incorporated in the model as an increase in the transfer limits	N

⁴ Final FCM sales that will materialize are unknowable at the time of the IRM study. To reflect the impact these sales have on reliability, the NYISO applies a Locality Exchange Factor in the market.

Topology

#	Parameter	2024 Model Assumptions	2025 Model Assumptions	Basis for Recommendation	Model Change
29	Interface Limits	Updates to the forward limits of Central East, Central East Group, Marcy South, Capital to Hudson Valley, UPNYSENY, and UPNY-ConED interfaces due to the partial completion of Segment B of the AC Transmission Project. The delay of the Dover PAR construction is captured.	Updates to the Central East forward limits, and West-Central reverse limit	Based on the most recent NYISO operating studies and processes	N
30	New Transmission	None Identified	None Identified	Based on TO provided models and NYISO's review	N
31	AC Cable Forced Outage Rates	All existing Cable EFORds for NYC and LI to reflect most recent five-year history (2018-2022) (Attachment E4)	All existing Cable EFORds for NYC and LI to reflect most recent ten-year history (2014-2023) (Attachment E4)	TO provided transition rates with NYISO review Based upon NYSRC recommendation	N
32	UDR Line Unavailability	Five-year history of forced outages (2018-2022)	Ten-year history of forced outages (2014-2023)	NYISO/TO review Based upon NYSRC recommendation	N

Emergency Operating Procedures

#	Parameter	2024 Model Assumptions	2025 Model Assumptions	Basis for Recommendation	Model Change
33	Special Case Resources (SCRs)	July 2023 - 1,281 MW based on registrations and modeled as 896.5 MW of effective capacity. Monthly variation based on historical experience.	July 2024 - 1,486.7 MW based on registrations and modeled with maximum capacity of 1,280.8 MW derated by hourly response rates. Utilize a new energy limited resource (ELR) functionality to model SCRs as duration limited resources with hourly response rates and limited to one call per day. Monthly variation based on historical experience.	Enhanced SCR Modeling Review	Y
34	Other Emergency Operating Procedures (EOPs)	400 MW of 10-min reserves maintained at load shedding 929.8 MW of non-SCR/non-EDRP resources (Attachment D)	400 MW of 10-min reserves maintained at load shedding Voluntary Curtailment and Public Appeals limited to 3 calls per year 804.6 MW of non-SCR/non-EDRP resources (Attachment D)	Based on Whitepaper and NYISO updated analysis recommendation Based on NYSRC recommendation Based on TO information, measured data, and NYISO forecasts	Y
35	EOP Structure	10 EOP steps modeled EOP order updated to align with the emergency operating procedure sequence	10 EOP steps modeled	Based on agreement with ICS	N

External Control Areas

#	Parameter	2024 Model Assumptions	2025 Model Assumptions	Basis for Recommendation	Model Change
36	PJM	Load and capacity data will be provided by PJM/NPCC CP-8 Data may be adjusted per NYSRC Policy 5. (Attachment E)	Load and capacity data will be provided by PJM/NPCC CP-8 Data may be adjusted per NYSRC Policy 5. (Attachment E)	Initial Review by the NPCC CP-8 WG prior to Policy 5	N
37	ISONE, Quebec, IESO	Load and capacity data will be provided by ISONE/NPCC CP-8 Data may be adjusted per NYSRC Policy 5. (Attachment E)	Load and capacity data will be provided by ISONE/NPCC CP-8 Data may be adjusted per NYSRC Policy 5. (Attachment E)	Initial Review by the NPCC CP-8 WG prior to Policy 5	N
38	External Adjustments per Policy 5	If needed, add load to externals proportional to existing excess capacity.	If needed, add load to externals proportional to existing excess capacity.	Whitepaper on External Control Area adjustments	N
39	Reserve Sharing	All NPCC Control Areas indicate that they will initially share reserves equally among all members and then non-members.	All NPCC Control Areas indicate that they will initially share reserves equally among all members and then non-members.	Per NPCC CP-8 WG	N
40	Emergency Assistance	Statewide emergency assistance allowed from neighbors: Bin 1: 1,470 MW Bin 2: 2,600 MW Bin 3-7: 3,500 MW Individual interface limits are also reduced by Bin	Statewide emergency assistance allowed from neighbors: Bin 1: 1,470 MW Bin 2: 2,600 MW Bin 3-7: 3,500 MW Individual interface limits and PJM cables are also reduced by Bin (Attachment E5)	Whitepaper on Modeling of Emergency Assistance for NYCA in IRM studies Based upon NYSRC recommendation	Y

Miscellaneous

#	Parameter	2024 Model Assumptions	2025 Model Assumptions	Basis for Recommendation	Model Change
41	MARS Model Version	4.14.2179	4.14.2179	Per testing and ICS recommendation	N
42	Environmental Initiatives	No new rules for 2024-2025 Capability Year	No new rules for 2025-2026 Capability Year	Review of existing regulations and rules	N

Attachment A1

NYCA Summer Load Forecast Coincident and Non-Coincident Peak: 2024-2025 Final Base Case (FBC) and 2025-2026 Preliminary Base Case (PBC)

2024-2025 FBC													
Area	A	B	C	D	E	F	G	H	I	J	K	NYCA	G_J
NCP - Forecast	2,764.0	2,095.9	2,766.8	711.5	1,360.7	2,324.8	2,177.2	638.9	1,410.0	11,170.6	5,080.3		
CP - Forecast	2,664.7	2,050.6	2,694.7	692.9	1,323.7	2,279.2	2,131.0	624.8	1,379.0	10,925.1	4,999.9	31,765.6	
G-J Peak - Forecast							2,161.2	633.7	1,398.5	11,080.1			15,273.5

2025-2026 PBC													
Area	A	B	C	D	E	F	G	H	I	J	K	NYCA	G_J
NCP - Forecast	2,929.5	2,067.3	2,692.2	708	1,355.8	2,318	2,204	629	1,364	11,227.5	5,077.9		
CP - Forecast	2,824.5	2,023.3	2,622.2	689	1,318.8	2,273	2,157	615	1,334	10,977.5	4,997.9	31,832.2	
G-J Peak - Forecast							2,188	624	1,353	11,133.5			15,298.5

Delta													
Area	A	B	C	D	E	F	G	H	I	J	K	NYCA	G_J
NCP - Forecast	165.5	-28.6	-74.6	-3.5	-4.9	-6.8	26.8	-9.9	-46.0	56.9	-2.4		
CP - Forecast	159.8	-27.3	-72.5	-3.9	-4.9	-6.2	26.0	-9.8	-45.0	52.4	-2.0	66.6	
G-J Peak - Forecast							26.8	-9.7	-45.5	53.4			25.0

Attachment A2

NYCA Summer Load Forecast Uncertainty Model: 2024 and 2025

Load Forecast 2024

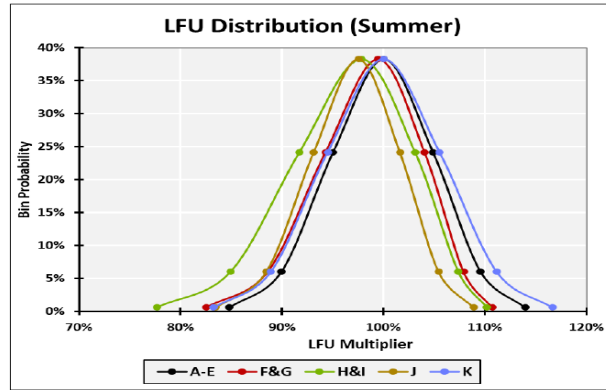

Load Forecast 2025

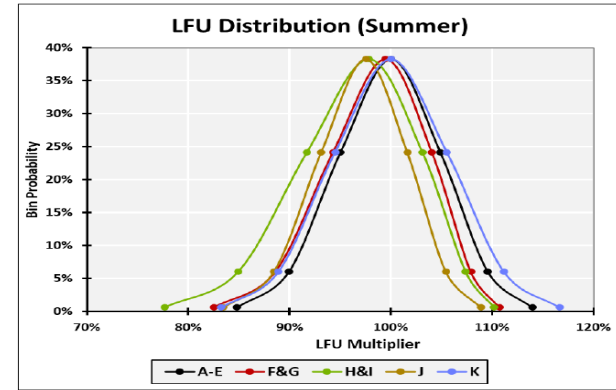

Bin	Bin z	Bin Probability	A-E	F&G	H&I	J	K
Bin 1	2.74	0.62%	113.93%	110.69%	110.18%	108.88%	116.62%
Bin 2	1.79	6.06%	109.54%	107.86%	107.34%	105.42%	111.14%
Bin 3	0.89	24.17%	104.86%	104.04%	103.09%	101.61%	105.52%
Bin 4	0.00	38.29%	100.00%	99.46%	97.81%	97.51%	100.00%
Bin 5	-0.89	24.17%	95.00%	94.29%	91.70%	93.12%	94.48%
Bin 6	-1.79	6.06%	89.91%	88.61%	84.93%	88.45%	88.89%
Bin 7	-2.74	0.62%	84.79%	82.53%	77.65%	83.48%	83.27%

Bin	Bin z	Bin Probability	A-E	F&G	H&I	J	K
Bin 1	2.74	0.62%	113.93%	110.69%	110.18%	108.88%	116.62%
Bin 2	1.79	6.06%	109.54%	107.86%	107.34%	105.42%	111.14%
Bin 3	0.89	24.17%	104.86%	104.04%	103.09%	101.61%	105.52%
Bin 4	0.00	38.29%	100.00%	99.46%	97.81%	97.51%	100.00%
Bin 5	-0.89	24.17%	95.00%	94.29%	91.70%	93.12%	94.48%
Bin 6	-1.79	6.06%	89.91%	88.61%	84.93%	88.45%	88.89%
Bin 7	-2.74	0.62%	84.79%	82.53%	77.65%	83.48%	83.27%

Attachment A3

NYCA Winter Load Forecast Uncertainty Model: 2025

Bin	Bin z	Bin Probability	NYCA
Bin 1	2.74	0.62%	110.37%
Bin 2	1.79	6.06%	106.37%
Bin 3	0.89	24.17%	102.75%
Bin 4	0.00	38.29%	99.42%
Bin 5	-0.89	24.17%	96.29%
Bin 6	-1.79	6.06%	93.30%
Bin 7	-2.74	0.62%	90.41%

Attachment B1

New Thermal Units and Unit Re-Ratings

New Thermal Units and Unit Re-ratings (summer ratings)					
Project or Generator Name	Zone	2024 Gold Book (MW) CRIS	2024 Gold Book (MW) DMNC	New or Incremental (MW)	2025 MARS Model (MW)
New Units					
New Athens Unit 1	F	316.6	329.4	12.2	328.8
New Athens Unit 2	F	315.6	333.3	17.1	332.7
New Athens Unit 3	F	312.8	331.1	17.7	330.5
Total New Units and Uprates (MW)				47.0	

Attachment B2

Deactivations and Removals

Unit Removal since 2024-2025 IRM Study			
Generator Name	Type	Zone	SUMMER CRIS (MW)
Arthur Kill Cogen	NG	J	11.1
Arthur Kill GT1	GT	J	16.5
Astoria GT1	GT	J	15.7
Glenwood GT03	GT	K	54.7
Shoreham 1	GT	K	48.9
Shoreham 2	JE	K	18.5
Total Removals			165.4

Attachment B3

New Intermittent Resources

New Intermittent Units				
Resource	Zone	CRIS (MW)	Summer Capability (MW)	MARS Modeled Capacity
Wind				
Total Wind				
Solar				
Morris Ridge Solar Energy Center	C	177.0	177.0	177.0
High River Solar	F	90.0	90.0	90.0
Total Solar				267

Attachment B4

New Energy Storage Resources

Energy Storage				
Resource	Zone	CRIS (MW)	Summer Capability (MW)	Lesser of Summer Capability VS CRIS
New Battery Units				
Total New Energy Storage				

Attachment B5

Resources in the Behind-the-Meter Net Generation (BTM:NG) Resource Program

Attachment B5 - Units in the Behind-the-Meter Net Generation Resource Program*			
Generator Name	Zone	Resource Value (MW) ⁵	Peak Load Adjustment (MW) ⁶
Existing:			
Stony Brook	K	0.0	41.9
Greenidge 4	C	102.8	63.2
Lyons Falls Hydro	E	0.0	1.8
KIAC_JFK	J	127.7	17.5
Red Rochester	B	79.4	54.3
Oxbow (Fortistar - N.Tonawanda)	A	57.4	3.5
Total BTM-NG			182.2

*The IRM study independently models the generation and load components of BTM:NG Resources.

⁵ Based on adjusted Dependable Maximum Gross Capability (DMGC) value.

⁶ Based on Average Coincident Host Load (ACHL).

Attachment C1

NYCA Five Year Derating Factors – All Resources

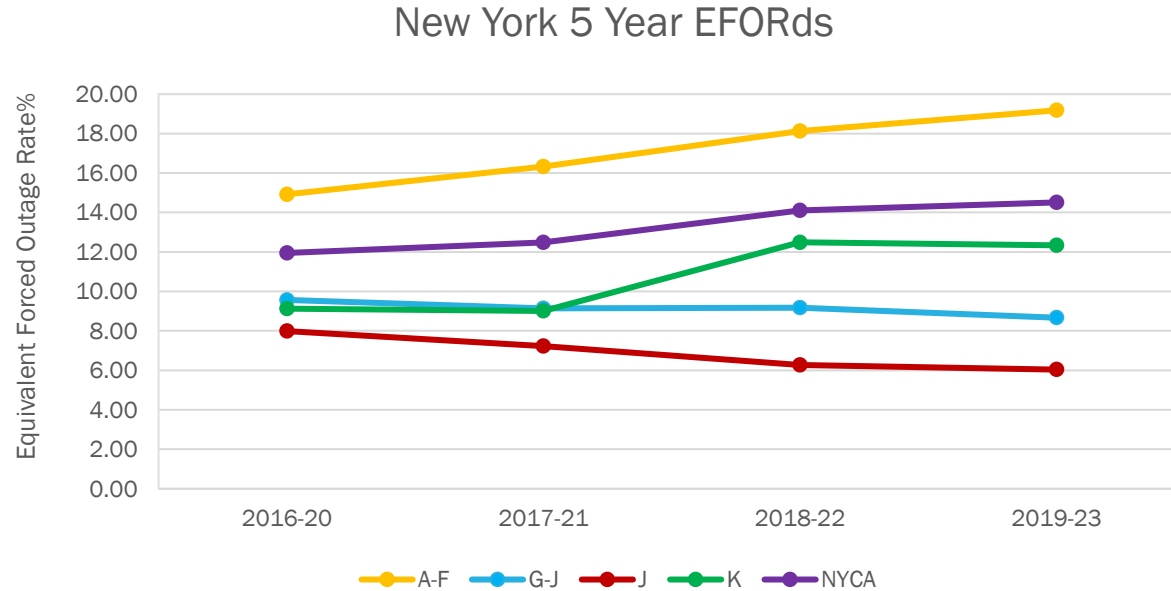

Attachment C2

NYCA Five Year Derating Factors - Intermittent Power Resources

New York 5 Year EFORds - Intermittent

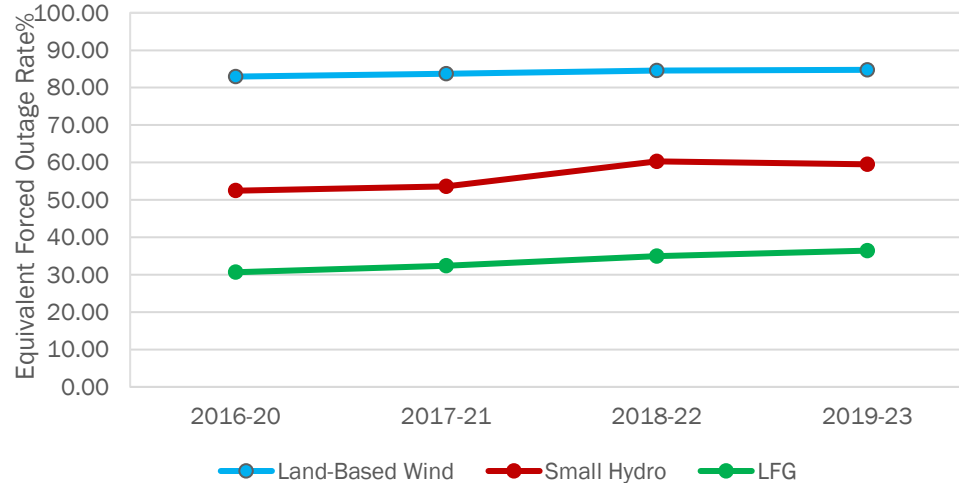

* Solar will be added when there are at least 3 units with production data for all 5 years of the applicable historical period

Attachment D

Emergency Operating Procedures

Step	Procedure	2024 IRM MW Value	2025 IRM MW Value
1	Special Case Resources – Load, Gen	1,281 MW Enrolled/ 896.5 MW Modeled	1,486.7 MW Enrolled / 1,280.8 MW Modeled
2	5% manual voltage Reduction	113.11 MW	63.38 MW
3	Thirty-minute reserve to zero	655 MW	655 MW
4	Voluntary industrial curtailment	267.17 MW	260.74 MW Limited to 3 calls per year
5	General Public Appeals	74 MW	74 MW Limited to 3 calls per year
6	5% remote voltage reduction	475.56 MW	406.49 MW
7	Emergency Purchases	Varies	Varies
8	Ten-minute reserves to zero	910 MW (400 MW maintained at load shedding)	910 MW (400 MW maintained at load shedding)
9	Customer disconnections	As needed	As needed
10	Adjustment used if IRM is lower than technical study margin	As needed	As needed

Attachment E3

PJM Bubble Model

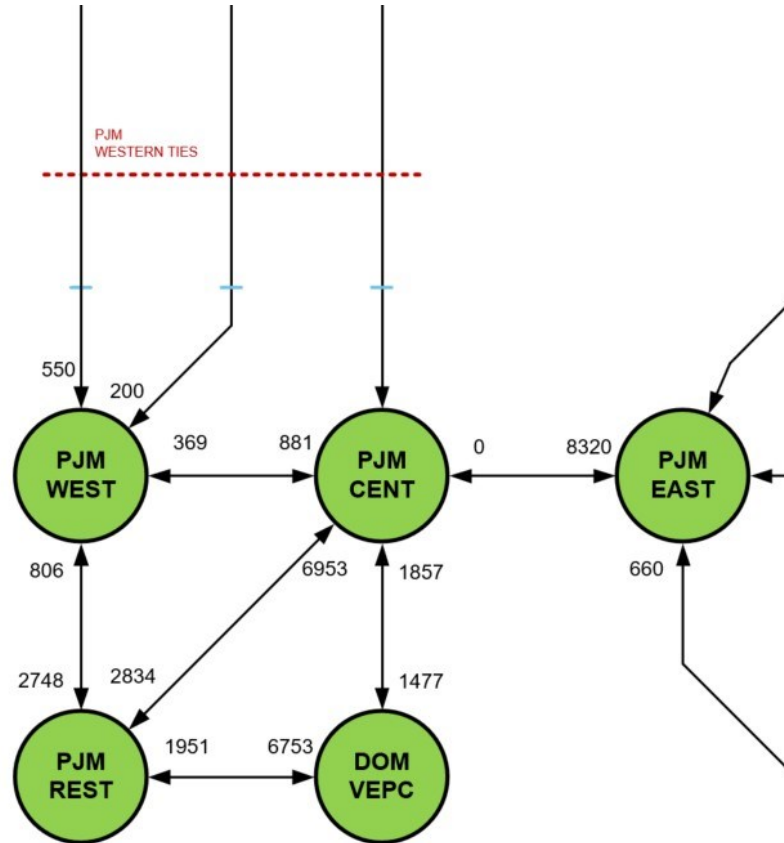

Attachment E4

Cable Outage Rate	
2018-22* (5-year average)	2014-23 (10-year average)
5.36%	5.31%

The facilities included in these averages are VFT, HTP, Dunwoodie-South, Y49/Y50, CSC, Neptune, Norwalk-Northport and A-Line.

*The 10-year average data is not available for the 2024-2025 IRM study

Attachment F

SCR Determinations 2024-2025 and 2025-2026 IRM Studies

SCR Performance for 2025-2026 IRM Study*									
Super Zones	SCR Enrollments (MW)	Response Rate (%) by Hour of SCR Activation							Superzonal ACL to CBL Translation Factor (%)
		Event Hour 1	Event Hour 2	Event Hour 3	Event Hour 4	Event Hour 5	Event Hour 6	Event Hour 7	
A - E	783.4	77.85%	83.57%	82.28%	70.24%	69.18%	0%	0%	93.45%
F	103.5	75.94%	82.20%	85.24%	86.18%	85.54%	70.40%	66.99%	90.58%
G - I	90.6	58.45%	67.53%	70.20%	71.94%	73.63%	71.48%	0%	84.07%
J	478.7	55.04%	60.60%	65.47%	67.78%	68.80%	66.09%	0%	74.29%
K	30.6	49.71%	56.72%	62.12%	64.63%	64.66%	63.36%	52.65%	76.11%
All Zones	1,486.7	62.01%	68.39%	71.35%	69.61%	69.93%	66.38%	58.14%	

*The SCR Performance for 2025-2026 IRM study reflects the [Enhanced SCR Modeling](#) construct

SCR Performance for 2024-2025 IRM Study						
Super Zones	Enrollments (July 2023 - estimated)	Forecast (2024) ⁶	Performance Factor ⁷	UCAP (2024)	Adjustment Factor ⁸	Model Value
A - F	719.1	719.1	0.871	626.3	0.942	589.8
G - I	84.3	84.3	0.778	65.5	0.843	55.3
J	442.4	442.4	0.706	312.4	0.745	232.7
K	35.4	35.3	0.698	24.6	0.762	18.8
Totals	1,281.0	1,281.0		1,028.9		896.5
					Overall Performance = 70.0%	

7. These values represent no growth from July ICAP based enrollments for the previous year. Differences in data in this column are due to software rounding updates since the 2023 IRM. Updated data aligns with 2023 Gold Book values.

8. Performance Factor based on ACL methodology.

9. The SCR Adjustment factor captures two different performance derates: (1) Calculated Translation Factor (TF) between ACL and CBL values and (2) the Fatigue Factor (FF=1.00).

Attachment G Wind Units Modeled

Wind				
Resource	Zone	CRIS (MW)	Summer Capability (MW)	MARS Modeled Capability**
Arkwright Summit Wind Farm [WT]	A	78.4	78.4	78.4
Ball Hill Wind [WT]	A	100.0	107.5	100.0
Bliss Wind Power [WT]	A	100.5	100.5	100.5
Baron Winds [WT]	C	300.0	121.8	121.8
Canandaigua Wind Power [WT]	C	125.0	125.0	125.0
Eight Point Wind Energy Center [WT]	C	101.2	111.2	101.2
High Sheldon Wind Farm [WT]	C	112.5	118.1	112.5
Howard Wind [WT]	C	57.4	55.4	55.4
Orangeville Wind Farm [WT]	C	94.4	93.9	93.9
Wethersfield Wind Power [WT]	C	126.0	126.0	126.0
Altona Wind Power [WT]	D	97.5	97.5	97.5
Chateaugay Wind Power [WT]	D	106.5	106.5	106.5
Clinton Wind Power [WT]	D	100.5	100.5	100.5
Ellenburg Wind Power [WT]	D	81.0	81.0	81.0
Jericho Rise Wind Farm [WT]	D	77.7	77.7	77.7
Marble River Wind [WT]	D	215.2	215.2	215.2
Bluestone Wind [WT]	E	124.2	111.8	111.8
Hardscrabble Wind [WT]	E	74.0	74.0	74.0
Madison Wind Power [WT]	E	11.5	11.6	11.5
Maple Ridge Wind [WTO1]	E	231.0	231.0	231.0
Maple Ridge Wind [WTO2]	E	90.7	90.8	90.7
Munnsville Wind Power [WT]	E	34.5	34.5	34.5
Number 3 Wind Energy [WT]	E	105.8	103.9	103.9
Roaring Brook [WT]	E	79.7	79.7	79.7
South Fork Wind Farm (Offshore)	K	136.0	136.0	136.0
Total		2,761.20	2,589.50	2,566.20

Attachment G1

Wind Units Not Currently Participating in ICAP Market

Wind					
Resource	Zone	Nameplate (MW)	CRIS (MW)	Summer Capability (MW)	MARS Modeled Capacity
Cassadaga Wind [WT]	A	126.5	126.0	0.0	0.0
Erie Wind [WT]	A	15.0	0.0	0.0	0.0
Steel Wind [WT]	A	20.0	0.0	0.0	0.0
Fenner Wind [WT]	C	30.0	30.0	0.0	0.0
Marsh Hill Wind Farm [WT]	C	16.2	0.0	0.0	0.0
Copenhagen Wind [WT]	E	79.9	79.9	0.0	0.0
Total		287.6	235.9	0.0	0.0

Attachment G2

Solar Units Modeled

Solar				
Resource	Zone	CRIS (MW)	Summer Capability (MW)	Lesser of Summer Capability vs. CRIS
Janis Solar [PV]	C	20.0	20.0	20.0
Morris Ridge Solar Energy Center	C	177.0	177.0	177.0
Puckett Solar [PV]	C	20.0	20.0	20.0
Albany County	F	20.0	20.0	20.0
Albany County II	F	20.0	20.0	20.0
Branscomb Solar [PV]	F	20.0	20.0	20.0
Darby Solar [PV]	F	20.0	20.0	20.0
East Point Solar	F	50.0	50.0	50.0
Grissom Solar [PV]	F	20.0	20.0	20.0
High River Solar	F	90.0	90.0	90.0
Pattersonville Solar [PV]	F	20.0	20.0	20.0
Regan Solar [PV]	F	20.0	20.0	20.0
ELP Stillwater Solar [PV]	F	20.0	20.0	20.0
Calverton Solar Energy Center [PV]	K	22.9	22.9	22.9
Long Island Solar Farm [PV]	K	31.5	31.5	31.5
Total		571.4	571.4	571.4

Attachment G3

Solar Units Not Modeled

Solar				
Resource	Zone	CRIS (MW)	Summer Capability (MW)	Lesser of Summer Capability vs. CRIS
Shoreham Solar [PV]*	K	25.0	0.0	0.0
Total		25.0	0.0	0.0

*Unit provides power at the distribution rather than at the transmission level.

Attachment G4

Landfill Gas (LFG) Units Modeled

LFG				
Resource	Zone	CRIS (MW)	Summer Capability (MW)	Lesser of Summer Capability VS CRIS
CHAFFEE [IC]	A	6.4	6.4	6.4
Model City Energy LFGE [IC]	A	5.6	5.6	5.6
Modern LFGE [IC]	A	6.4	6.4	6.4
Hyland LFGE [IC]	B	4.8	4.8	4.8
Mill Seat [IC]	B	6.4	6.4	6.4
Broome 2 [IC]	C	2.0	2.1	2.0
Broome LFGE [IC]	C	2.1	2.4	2.1
High Acres Group [IC] (23767)	C	9.6	9.6	9.6
Ontario LFGE [IC]	C	11.2	11.2	11.2
Seneca Energy Group [IC] (23797)	C	17.6	17.6	17.6
Clinton LFGE [IC]	D	6.4	6.4	6.4
DANC LFGE [IC]	E	6.4	6.4	6.4
Oneida-Herkimer LFGE [IC]	E	3.2	3.2	3.2
Colonie LFGTE [IC]	F	6.4	6.4	6.4
Fulton County Landfill [IC]	F	3.2	3.2	3.2
Albany LFGE	F	4.5	5.6	4.5
Totals		102.2	103.7	102.2

Attachment G5

Landfill Gas (LFG) Units Not Modeled

LFG				
Resource	Zone	CRIS (MW)	Summer Capability (MW)	Lesser of Summer Capability VS CRIS
Chautauqua LFGE	A	9.6	0.0	0.0
Synergy Biogas	B	2.0	0.0	0.0
Madison County LFGE [IC]	E	1.6	0.0	0.0
Total		13.2	0.0	0.0

Assumption Matrix History

Date	Ver	Preliminary Base Case	Date	Ver	Final Base Case
01/19/2024	V0.0	Preliminary assumptions without attachments	09/04/2024	V0.0	Preliminary assumptions with updates to Attachments B2, C (addition of C2 for Intermittent Power Resources), D, E4, and F
02/21/2024	V1.0	Addition of proposed Attachment H (pending approval of Gas Constraints Modeling Whitepaper)	10/02/2024	V1.0	Preliminary assumptions with updates to Item Item No. 7, Item No. 15, Item No. 34, Item No. 42, as well as Attachments B1, B3, C1, C2, D, E1, E2, and G2
03/28/2024	V2.0	Preliminary assumptions and Attachments C and H (pending approval of Gas Constraints Modeling Whitepaper)			
04/25/2024	V3.0	Preliminary assumptions, Attachment A1, Attachment D and Attachment F			
05/28/2024	V4.0	Preliminary assumptions, Attachments A1-3, B2, B5, D, E4, G, G1, and removed proposed Attachment H consistent with recommendation to study fuel availability constraints as sensitivities to the 2025-2026 IRM study			
06/20/2024	V5.0	Preliminary assumptions, Attachments B3, C, D, E1-3 and G2			
06/26/2024	V5.1	Preliminary assumptions, Attachments D, E1, E4 and the proposed addition of Attachment E5			